

# BLASTHOLE DRILLS



PRODUCTIVE  
RELIABLE  
ECONOMICAL

HIGH-PERFORMANCE DRILLING OPTIONS. MORE PRODUCTIVITY. LESS MAINTENANCE. [www.frdusa.com](http://www.frdusa.com)

# INSIDE FURUKAWA ROCK DRILL USA

## TRADITION AND HIGH-TECH FROM ONE COUNTRY

Furukawa Rock Drill USA is a wholly owned subsidiary of FURUKAWA ROCK DRILL CO., LTD. Furukawa was founded in 1875 by Ichibei Furukawa to mine and smelt copper. The business steadily expanded to include FRD USA which includes the Breaker/Attachment Division (formerly Kent Demolition Tools) specializing in attachments for skid steer, mini excavators, backhoes and excavators. The Fx Series Furukawa hydraulic breaker is now a leading brand throughout North and Central America.

Our Rock Drill Division offers a complete line of advanced blasthole drills and accessories for construction and quarry sites. As a technology company our products are always on the leading edge, driving equipment advancements.

FURUKAWA CO., Ltd. has diversified over the years to become a leading corporation in Japan. Today, in addition to mining and smelting we also manufacture machinery, electronic materials and chemicals, as well as supply fuel and electric power.





## CONTENT

Inside Furukawa USA	2/3
HD800 Series Drifter	4/5
HCR900-ESV	6/9
HCR1100-ED	10/13
HCR1100-ER	14/17
HCRL90-E5	18/21
HCRL110	22/25
HCR Specifications	26/27
DCRL130	28/31
DCR Specifications	32
Options	33
PCR200	34/35
Service & Support	36/38
Breaker Attachment Division	39

High-performance drilling options. More productivity. Less maintenance.

## Designed Specifically for FRD Tier IV Drills

HD818 · HD822 · HD828S · HD828 · HD836

### Better Penetration with Increased Impact

- The Furukawa HD800 Series drifter (patent applied for) is designed to minimize drill noise and vibration, while increasing performance.
- With 20% more impact, this drill has the ability to perform in harder rock at a larger diameter.

### Dual Damper System DDS

- Stabilizes the bit against the rock, ensuring efficient energy transfer and straighter holes.
- Adjusts to rock conditions for optimized proficient drilling performance and increased drill tool life.

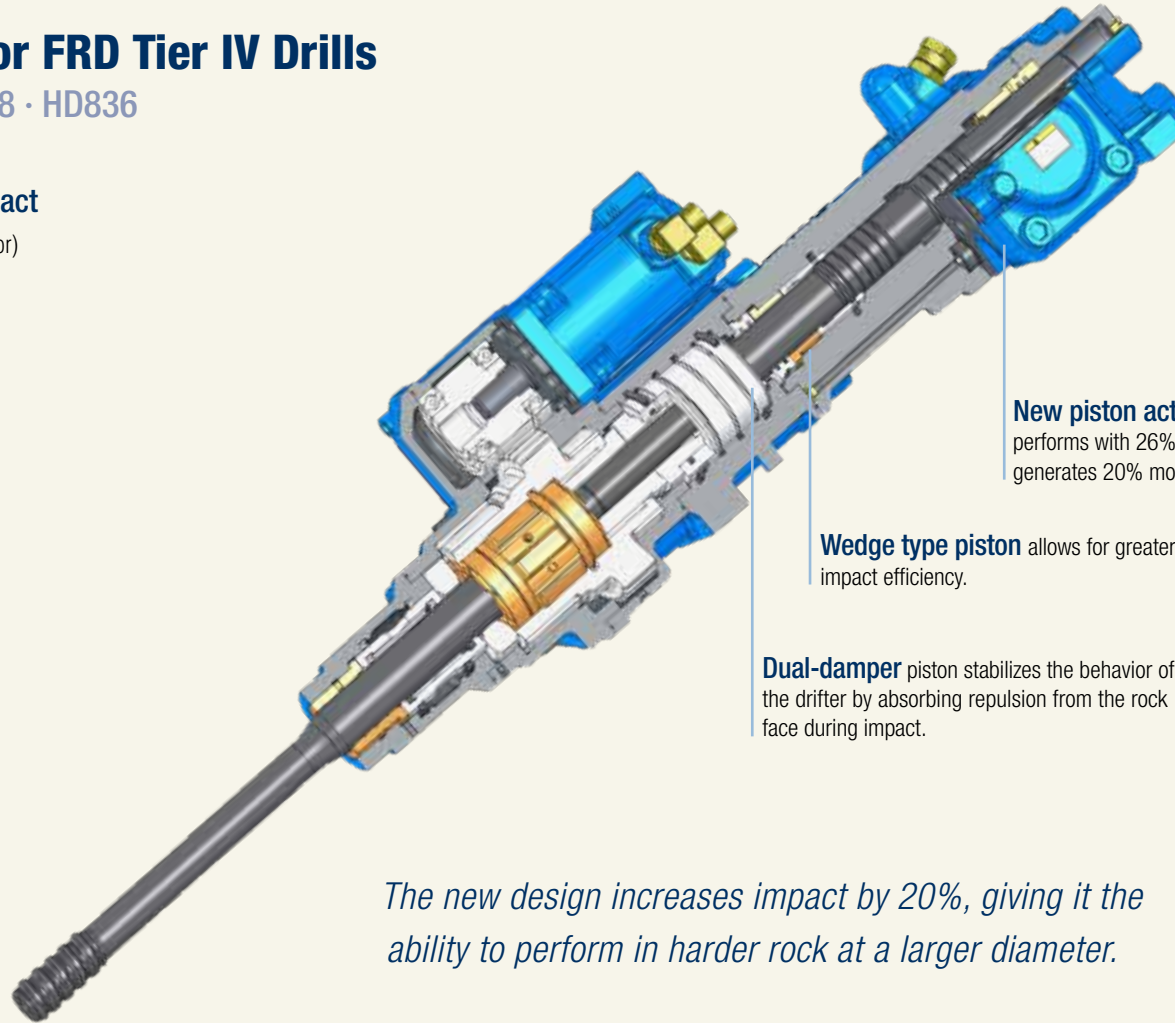

#### New piston actuating mechanism

performs with 26% more percussion and generates 20% more power at the same time.

**Wedge type piston** allows for greater impact efficiency.

**Dual-damper** piston stabilizes the behavior of the drifter by absorbing repulsion from the rock face during impact.

*The new design increases impact by 20%, giving it the ability to perform in harder rock at a larger diameter.*



# HD800 SERIES DRIFTER

	HD818		HD822		HD828S		HD828		HD836	
	US Standard	Metric	US Standard	Metric	US Standard	Metric	US Standard	Metric	US Standard	Metric
Drill Compatibility	HCR900ESV / HCR1100-ED		HCR1100-ER		HCRL90		HCRL110		HCRL110	
Maximum Impact Pressure	2,900 psi	20 MPa	2,900 psi	20 MPa	3,118 psi	21.5 MPa	2,900 psi	20 MPa	3,335 psi	23 MPa
Blow – Long Stroke	2,800 bpm		2,700 bpm		2,500 bpm		2,700 bpm		2,600 bpm	
Blow – Short Stroke	3,400 bpm		3,300 bpm		3,000 bpm		3,300 bpm		3,100 bpm	
Stroke Adjustment	Variable		Variable		Variable		Variable		Variable	
Maximum Rotation Torque	508 ft-lbs	689 Nm	1,045 ft-lbs	1,417 Nm	1,045 ft-lbs	1,417 Nm	1,045 ft-lbs	1,417 Nm	2,179 ft-lbs	2,955 Nm
Maximum Number of Rotations Per Minute	200		190		190		190		120	
Flushing System	Swivel Type		Swivel Type		Swivel Type		Swivel Type		Swivel Type	

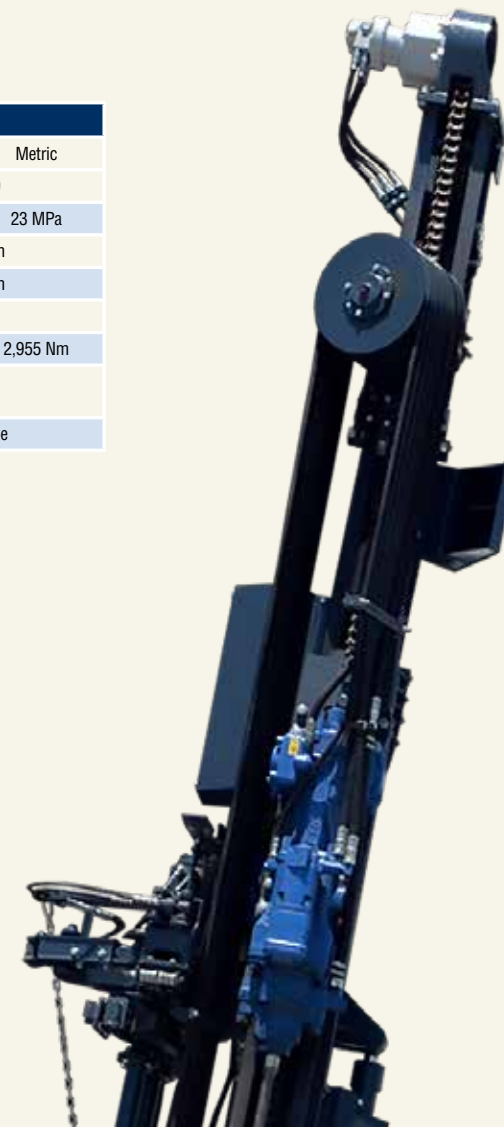

High-performance drilling options. More productivity. Less maintenance.

## Innovative Features For Higher Performance

### Combining Performance and Economy

The HCR900-ESV is simple, durable and efficient, providing a perfect solution for drilling in construction sites. The extendable boom incorporates a self-adjusting drill system that ensures high productivity in any drilling situation. What's more, the HCR900-ESV lends itself to control impact, feed, rotation force, and the dual dampening drifter continuously allows adapting to changing rock conditions. This results in increased drilling performance thus, optimizing fuel consumption and drill tool life.

### Improve your Drilling Precision with the Furukawa HD818 Drifter

This innovative drifter, for which patent application has been filed, is specifically designed to reduce drill noise and vibration, while boosting percussion frequency by 24% compared to its predecessor, the HD709 drifter.

The dual-dampening system ensures stability of the bit against the rock, which optimizes energy transfer and results in more accurate holes.

Additionally, adjusting the drifter will ensure maximum performance, no matter what the rock condition is.



# HCR900-ESV



### Maximize Operator Performance with the Ultimate in Drilling Technology

Ergonomically designed controls to minimize operator fatigue. The engine, compressor and hydraulic oil temperature gauges are highly visible, allowing the operator to monitor machine functions while remaining focused on the drilling.

### High Output Compressor and Dust Collector

The dust collector is equipped with an effective pre-cleaner that has the same suction capacity as previous models and reduces drilling dust leakage. An optional water/dust suppression system is available for dusty drilling conditions.

High-performance drilling options. More productivity. Less maintenance.

## Innovative Features for Higher Performance

- Low emission, Tier-IV Cummins® engine meets strict North American exhaust emissions regulations.
- Winch-ready frame adds application versatility.

### Also increases:

- Impact rates up to 3,400 blows per minute.
- Free air delivery up to 215 cfm (6.1 m<sup>3</sup>/min).
- Traction up to 16,636 lb-force (74.0 kN).
- Shoe width up to 12" (300 mm).
- Dust collector capacity up to 706 cfm (20 m<sup>3</sup>/min.).
- Suction hose size up to 4" (100 mm).



Left Access Cover



Right Access Cover



### Right Access Cover

Easy access to filters and battery.

### Left Access Cover

Easy access to fluid level, gauges and engine maintenance points.

### Rear Panel

Cooling systems located in the rear, providing quieter work environment for the operator.

# HCR900-ESV



# Dimensions

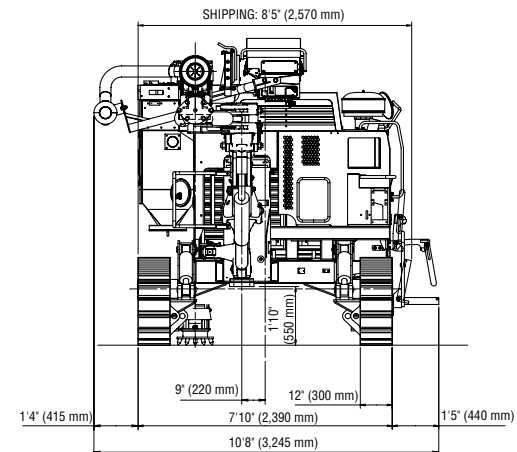
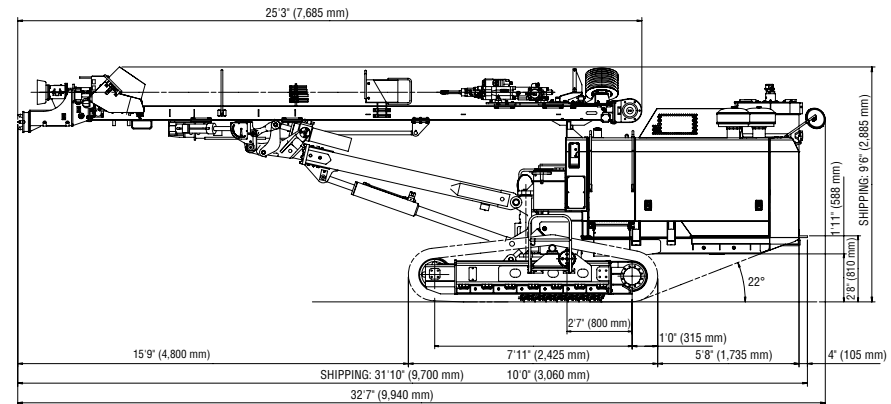
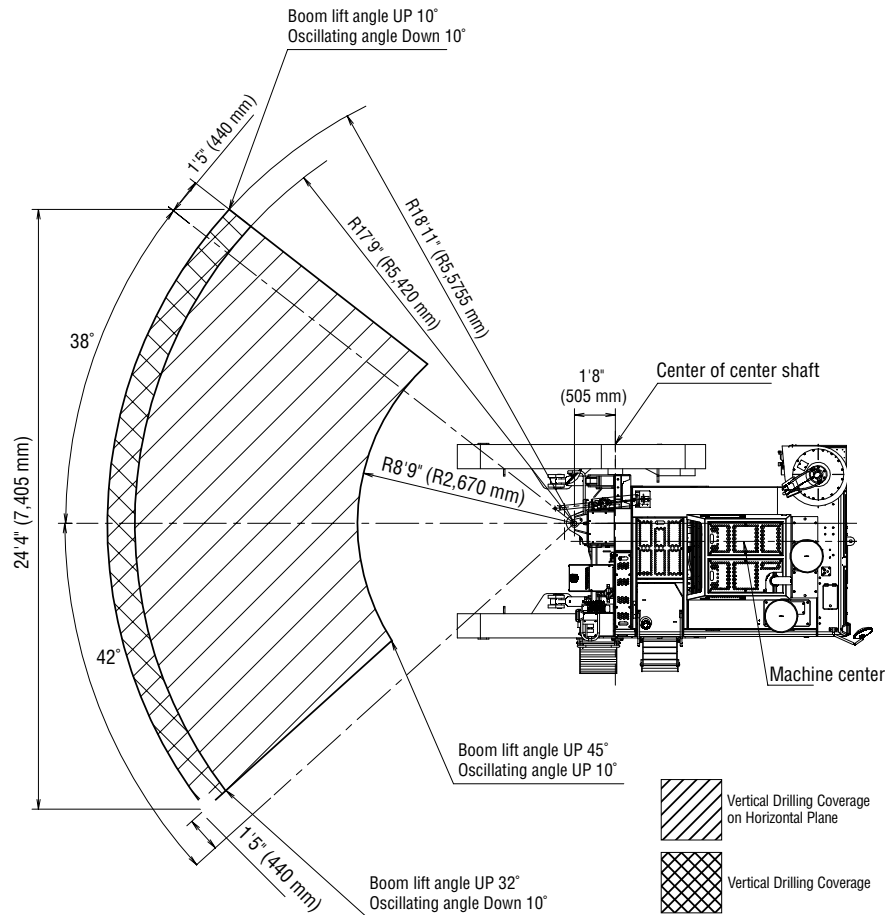

High-performance drilling options. More productivity. Less maintenance.

## Innovative Features For Higher Performance

### Combining Performance and Economy

Combining performance and economy, the HCR1100-ED is the perfect drill for quarries or construction sites. Simple, durable and efficient, the HCR1100-ED with incorporated extendable boom, ensures high productivity regardless the drilling condition. By controlling the impact force, feed force, rotation force and dual damper pressure, the HCR1100-ED continuously adapts to the changing rock conditions, increasing drilling performance and the life of drill tools while decreasing fuel consumption.

### Revolutionize Your Drilling Game with the Furukawa HD818 Drifter

The HD818 drifter minimizes annoying drill noise and vibrations. It also provides 24% higher percussion frequency over its predecessor, the HD709 drifter.

The Furukawa drifter utilizes a cutting-edge dual-dampening system that stabilizes the drill bit against the rock, resulting in highly efficient energy transfer and precise holes.

In addition, the dual dampening system allows adapting the drifter to accommodate changing rock conditions.



*Sliding suction cup  
minimizes dust for  
better visibility.*



# HCR1100-ED



*Cab designed for increased visibility.*



*The monitoring system incorporates gauges in the cabin, allowing the operator a quick visual of engine temperature, hydraulic oil temperature and fluid levels.*



### **Maximize Operator Performance with the Ultimate in Ergonomic Cab Designs**

HCR1100-ED ROPS cabs are ergonomically friendly with features that reduce operator fatigue. In addition, all cabs are air-conditioned and continuously pressurized with filtered air to maintain a comfortable operating environment.

### **Manage Fuel Savings**

With FRD's TFSS (total fuel savings system), the operator selects the optimum engine speed for the application, allowing all fuel savings functions to be automatically managed during drilling operation.

## Added Features Bring Versatility

- Low emission, Tier-IV Cummins® engine meets strict North American exhaust emissions regulations.
- Rod changer with proven design allows for the install of five drill steels plus one 13' starter rod.
- Heavy-duty undercarriage – featuring a pentagonal section design to reduce dirt build-up and track wear – ensures strength and durability.
- High-output compressor provides faster drilling and decreases bit wear.
- Reliable dust control system provides effective pre-cleaner to reduce escape of drilling dust.
- Single-lever drilling control for easy operation.
- Walk-around ground level maintenance provides fast, easy upkeep or repair.

### Options available:

- 2D/3D angle indicator.
- Dust suppression system.
- Heavy-duty rear-mounted bumper.
- Cold-start kit.
- Rear camera.
- Water kit.



#### Right Access Cover

Easy access to filters and battery.

#### Left Access Cover

Easy access to fluid level, gauges and engine maintenance points.

#### Rear Panel

Cooling systems located in the rear, providing quieter work environment for the operator.

#### Enhanced Undercarriage Design

Increases traction up to 19,700 16-force.



# HCR1100-ED

# Dimensions

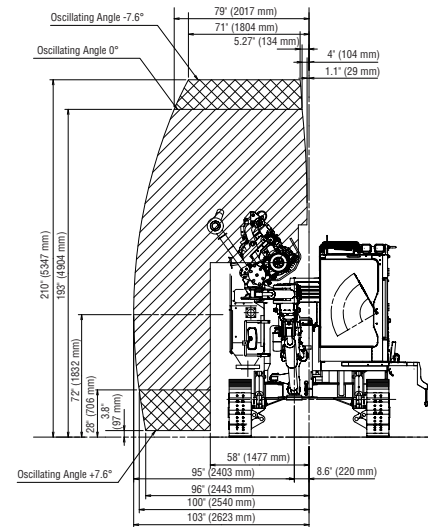
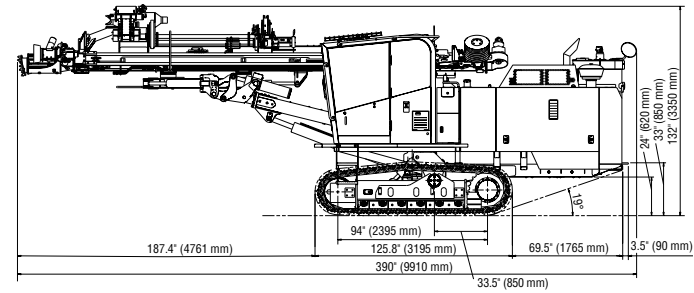
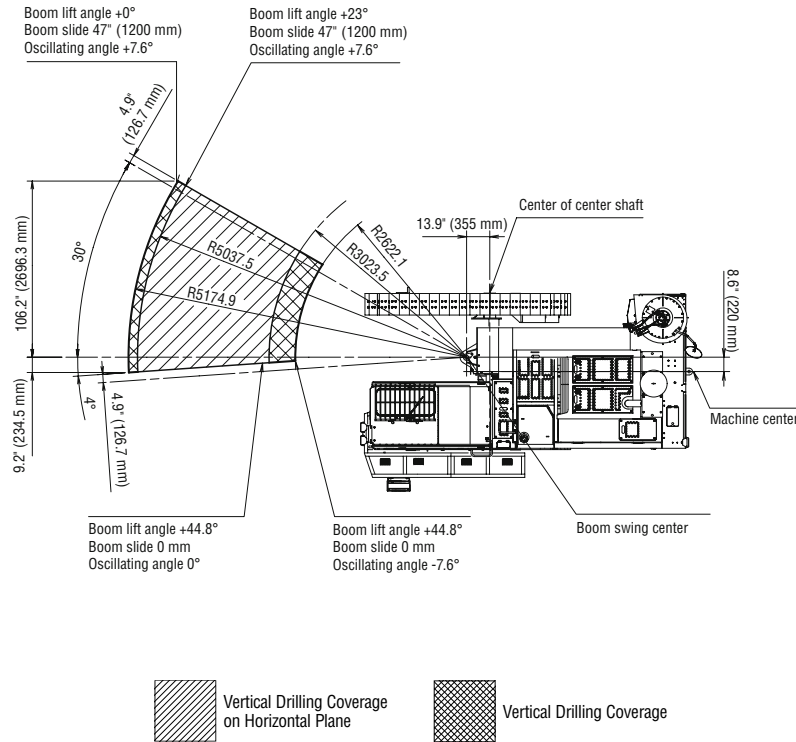

## Better Penetration with Increased Impact

The HCR1100-ER drill incorporates innovative features for higher output, capable of drilling at larger diameters. Utilizing a Cummins® Tier-IV EPA compliant engine, the HCR1100-ER combines higher performance with fuel efficiency.

### Higher Output with the HD822 Drifter

The Furukawa HD822 drifter (patent applied for) is designed to minimize drill noise and vibration, while increasing performance. With 28% more air flow than its predecessor, this drill has the ability to perform in harder rock at a larger diameter.

- New design increases percussion frequency by 20% versus the HD709 drifter.
- Dual dampening system stabilizes the bit against the rock, ensuring efficient energy transfer and straighter holes. The system automatically adjusts the drifter for maximum performance regardless of the rock condition.



HD822 Drifter



# HCR1100-ER



*Winch-Ready Frame*



### Improved Operator Control Station Complies with Industry Regulations

The relocated control station keeps the operator away from drill rotation and dust from drilling.

- ▶ The improved electro-hydraulics allows for easier operation.
- ▶ With FRD's TFSS (total fuel savings system), the operator selects the optimum engine speed for the application, allowing all fuel savings functions to be automatically managed during drilling operation.
- ▶ The monitoring system incorporates gauges next to the drilling station, allowing the operator a quick visual reference of engine temperature, hydraulic oil temperature and fluid levels.



*Improved Operator Control Station*

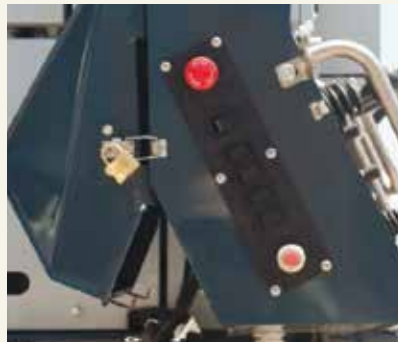

*Automatic Rod Changer*

### Automatic Rod Changer

Incorporates an automatic rod changer to eliminate the need for operators to manually install drill steels, resulting in increased production and enhanced operator safety.

### Upgraded Compressor

The upgraded 275 cfm compressor delivers greater air flow to allow for larger diameter and deeper hole drilling to optimize machine versatility.

## Innovative Features for Higher Performance

- Low emission, Tier-IV Cummins® engine meets strict North American exhaust emissions regulations.
- Rod changer with proven design allows for the install of five drill steels plus one starter rod.
- Winch-ready frame adds application versatility.
- Optional wireless remote allows tramping and drilling from a secondary location.

### Also increases:

- Impact rates up to 3,300 blows per minute.
- Free air delivery up to 275 cfm.
- Traction up to 19,700 lb-force.
- Shoe width up to 13" (330 mm).
- Dust collector capacity up to 918 cfm (26 m<sup>3</sup>/min.).
- Suction hose size up to 5" (125 mm).



### Right Access Cover

Easy access to filters and battery.

### Left Access Cover

Easy access to fluid level, gauges and engine maintenance points.

### Rear Panel

Cooling systems located in the rear, providing quieter work environment for the operator.

# HCR1100-ER



# Dimensions

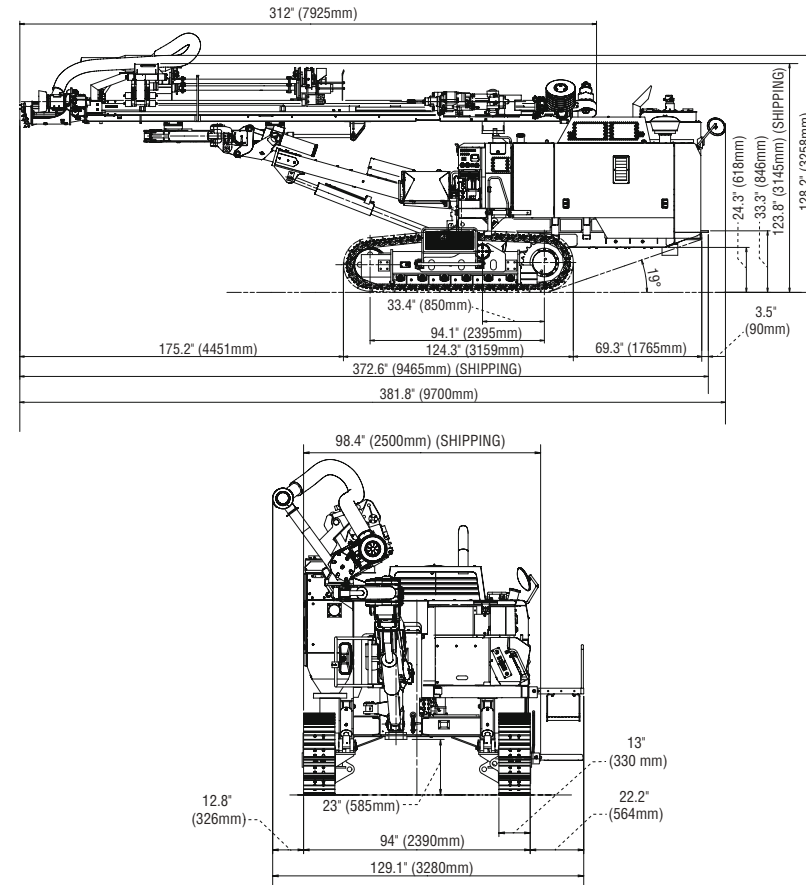
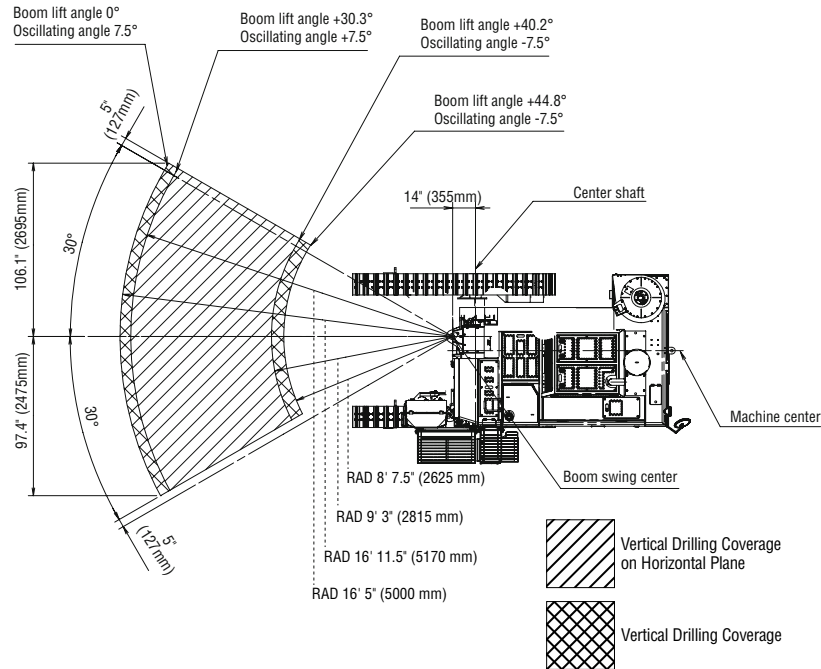

High-performance drilling options. More productivity. Less maintenance.

## Innovative Features For Higher Performance

### Drill Faster and Straighter with the HD828S Drifter

The Furukawa HD828S drifter combines powerful penetration with agility and easy operation. Equipped with features that maximize efficiency, the HD828S drifter sets the standard in high-performance drilling:

- The dual dampening system maximizes energy transfer to produce straighter holes and optimizes efficiency. The system continuously allows adapting to changing rock conditions.
- The hydraulic controls continuously allow impact, feed and rotation tuning in conjunction with the dual dampening control to accommodate changing rock conditions.



# HCRL90-E5



### Maximize Operator Performance with the Ultimate in Ergonomic Cab Designs

HCRL90-E5 cabs are ergonomically friendly with features that reduce operator fatigue. Cabs are 43" (1,100mm) with ROPS/FOPS standard. In addition, all cabs are air-conditioned and continuously pressurized with filtered air to maintain a comfortable operating environment. Other features include:

- ▶ Rubber-mounted engine frame isolates cab from engine vibrations.
- ▶ Single-lever drilling control for easy operation.
- ▶ Large windows maximize operator visibility.
- ▶ Walk-around ground level maintenance provides fast, easy upkeep or repair.
- ▶ All-In-One display allows operator to monitor machine functions while remaining focused on the drilling.

### Manage Fuel Savings

With FRD's TFSS (total fuel savings system), the operator selects the optimum engine speed for the application, allowing all fuel savings functions to be automatically managed during drilling operation.

### Combining Performance and Economy

Combining performance and economy, the HCRL90-E5 is the perfect drill for quarries or construction sites. Simple, durable and efficient, the HCRL90-E5 with extendable boom incorporates a self-adjusting drill system that ensures high productivity no matter what the drilling situation. What's more, the HCRL90-E5 lends itself to control impact, feed, rotation force, and the dual dampening drifter continuously allows adapting to changing rock conditions. This results in increased drilling performance thus, optimizing fuel consumption and drill tool life.

## Added Features Bring Versatility

- ▶ Low-emission Tier-IV/Stage V engines offer low fuel consumption and meets US exhaust emissions regulations.
- ▶ Advanced rotary rod changer allows easy drill rod changes. Operators can add and remove rods using a single lever.
- ▶ HCRL90-E5 features 12' rods with extendable boom for increased drill pattern.
- ▶ Heavy-duty undercarriage – featuring a pentagonal section design to reduce dirt build-up and track wear – ensures strength and durability.
- ▶ High-output compressor increases flushing air, provides faster drilling and decreases bit wear.
- ▶ Reliable dust control system increases suction capacity and provides effective pre-cleaner to reduce escape of drilling dust. An optional dust suppression system is available for difficult drilling conditions.

### Options available:

- 2D/3D angle indicator.
- Water dust suppression.
- Heavy-duty rear-mounted bumper.
- Cold-start kit.
- Rear camera.



# HCRL90-E5

# Dimensions

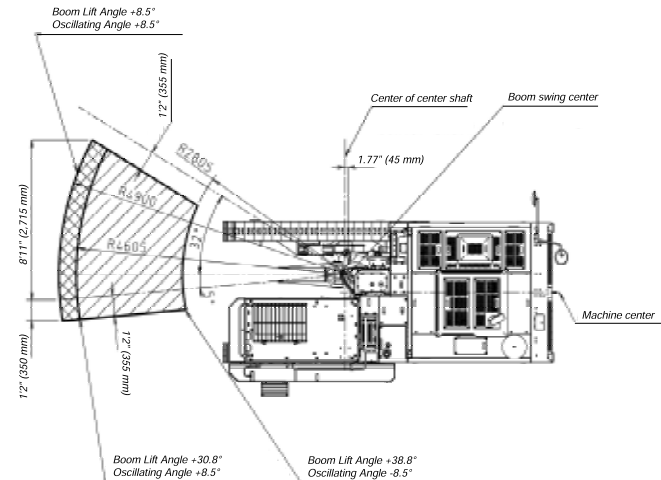
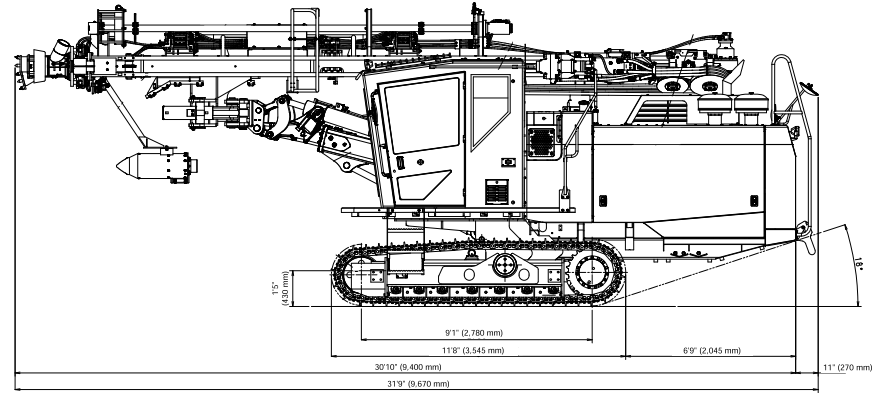
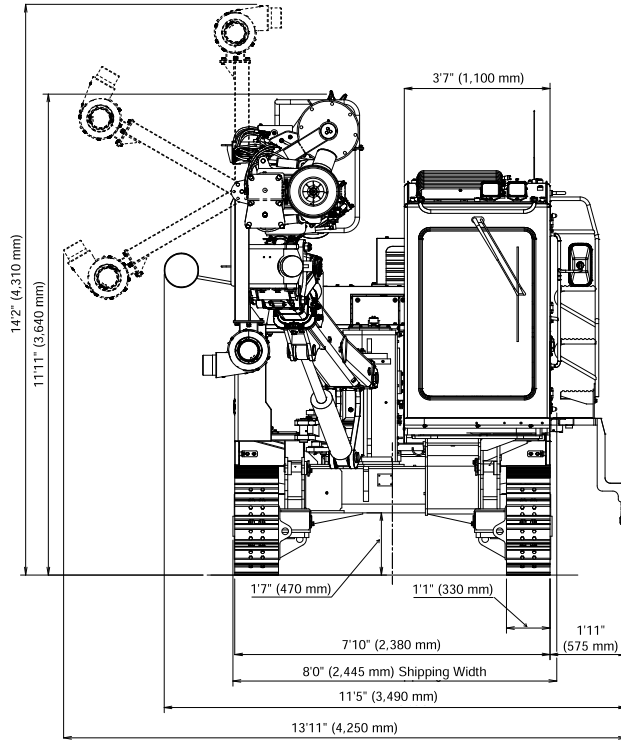

## Two Drifter Options for Increased Versatility

### Choose the Best Drifter for Your Job

The HCRL110 allows you to choose from two different drifters, depending on your specific application needs.

#### The HD828 drifter:

- Hole diameters from 4" to 5"
- Operates at up to 190 rpms
- Blow speed of 2,700 - 3,300 bpm.

#### The HD836 drifter:

- Hole diameters from 4" to 6"
- Operates at up to 120 rpms
- Blow speed of 2,600 - 3,100 bpm.

Use the HD828 drifter to drill holes from 4" to 5", or step up to the HD836 drifter for holes from 4" to 6" (using GT60 drill steel).

Whether you choose the HD828 drifter or the HD836, you will benefit from dependable performance and easy operation.



# HCRL110-E5



### Maximize Operator Performance with the Ultimate in Ergonomic Cab Designs

HCRL110 cabs are ergonomically friendly with features that reduce operator fatigue. Cabs are 51" (1,300mm) with ROPS/FOPS standard. In addition, all cabs are air-conditioned and continuously pressurized with filtered air to maintain a comfortable operating environment. Other features include:

- ▶ Rubber-mounted engine frame isolates cab from engine vibrations.
- ▶ Joy stick drilling control for easy operation.
- ▶ Large windows maximize operator visibility.
- ▶ Walk-around ground level maintenance provides fast, easy upkeep or repair.
- ▶ All-In-One display allows operator to monitor machine functions while remaining focused on the drilling.



### Manage Fuel Savings

With FRD's TFSS (total fuel savings system), the operator selects the optimum engine speed for the application, allowing all fuel savings functions to be automatically managed during drilling operation.

### Combining Performance and Economy

The combined performance and economy of the HCRL110 is the perfect drill for construction sites and quarries. Efficient, simple and durable the HCRL110 series ensure high productivity no matter what the drilling situation incorporated by the fully adjustable drill system. The HCRL110 continuously adapts to the changing rock conditions, by automatically controlling the impact force, feed force, rotation force and dual damper pressure, while decreasing fuel consumption, it's increasing drilling performance and the life the drill tools.

## Added Features Bring Versatility

- Low-emission C9.3B engine offers low fuel consumption and meets US exhaust emissions regulations.
- Advanced rotary rod changer allows easy drill rod changes. Operators can add and remove rods using a single lever.
- HCRL110-E5 features 12' or 14' rods with extendable boom for increased drill pattern.
- Heavy-duty undercarriage – featuring a pentagonal section design to reduce dirt build-up and track wear – ensures strength and durability.
- High-output compressor increases flushing air, provides faster drilling and decreases bit wear.
- Reliable dust control system with increased suction capacity provides effective pre-cleaning to reduce the escape of rock dust. An optional dust suppression system is available for difficult drilling conditions.
- Choose from an HD828 or HD836 drifter to meet your specific application needs.

### Options available, but not limited to:

- 2D/3D angle indicator.
- Water dust suppression.
- Heavy-duty rear-mounted bumper.
- Cold-start kit.
- Rear camera.



# HCRL110-E5



# Dimensions

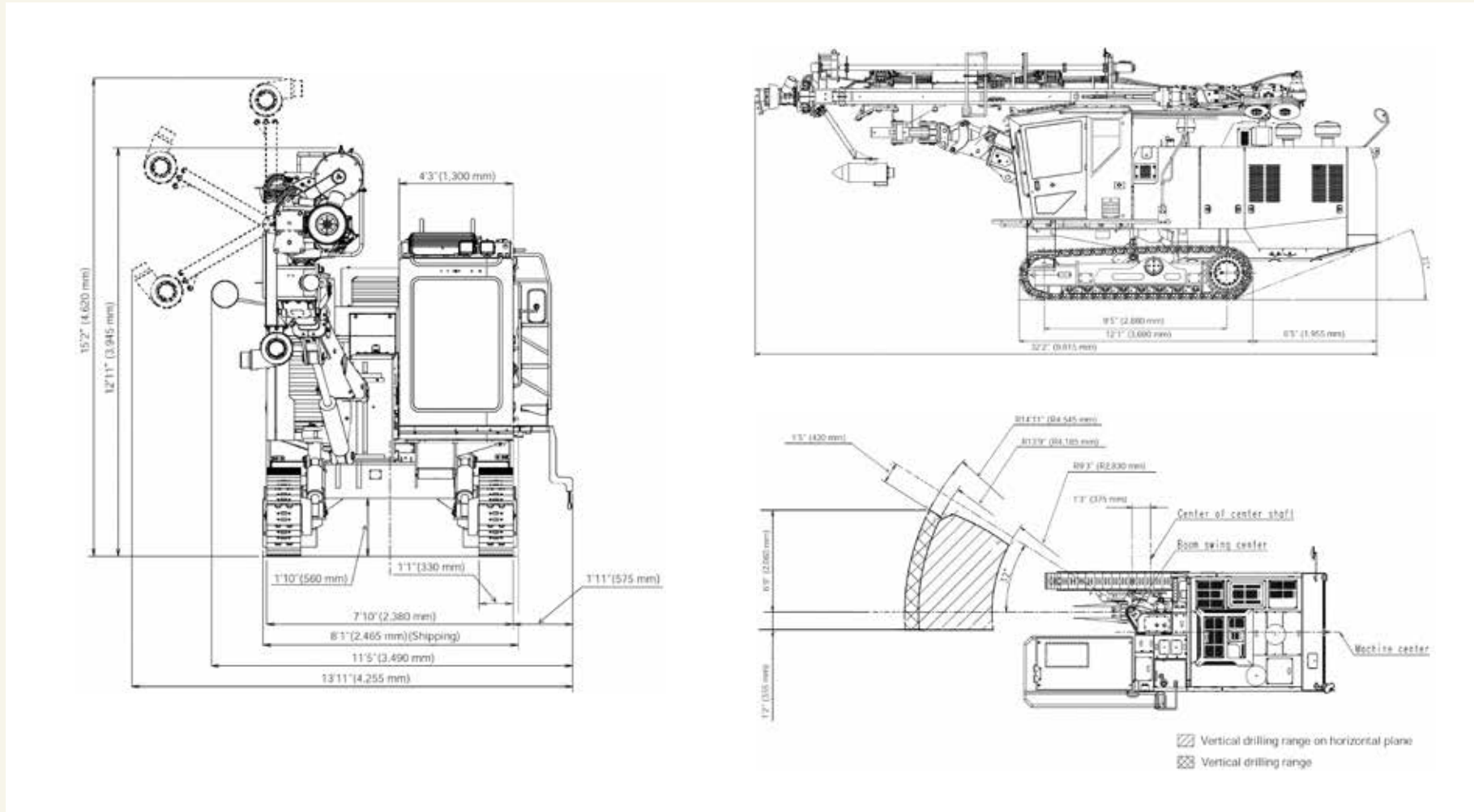

High-performance drilling options. More productivity. Less maintenance.

Model		HCR900-ESV		HCR1100-ED		HCR1100-ER		HCR190-E5		HCR110 WITH HD828 DRIFTER		HCR110 WITH HD836 DRIFTER	
		US Standard	Metric	US Standard	Metric	US Standard	Metric	US Standard	Metric	US Standard	Metric	US Standard	Metric
Dimensions and Weight	Overall Weight (A) *1	24,317 lb	11,030 kg	28,991 lb	13,150 kg	27,514 lb	12,480 kg	37,060 lb	16,810 kg	43,541 lb	19,750 kg	43,541 lb	19,750 kg
	Overall Weight (B) *2	24,978 lb	11,330 kg	29,784 lb	13,510 kg	28,351 lb	12,860 kg	38,647 lb	17,530 kg	45,415 lb	20,600 kg	45,415 lb	20,600 kg
	Overall Length	32'7"	9,940 mm	32'6"	9,910 mm	32'10"	10,020 mm	31'9"	9,670 mm	32'10"	10,015 mm	32'10"	10,015 mm
	Shipping Length	31'10"	9,700 mm	31'4"	9,545 mm	31'5"	9,575 mm	35'7"	10,855 mm	36'7"	11,160 mm	36'7"	11,160 mm
	Overall Width	10'8"	3,245 mm	10'6"	3,200 mm	10'4"	3,160 mm	11'5"	3,490 mm	11'5"	3,490 mm	11'5"	3,490 mm
	Shipping Width	8'5"	2,570 mm	7'10"	2,400 mm	8'2"	2,500 mm	8'0"	2,445 mm	8'1"	2,465 mm	8'1"	2,465 mm
	Overall Height	9'6"	2,885 mm	10'12"	3,350 mm	11'0"	3,350 mm	14'2"	4,310 mm	15'2"	4,620 mm	15'2"	4,620 mm
	Shipping Height	9'6"	2,885 mm	10'2"	3,100 mm	10'2"	3,110 mm	11'1"	3,375 mm	11'7"	3,520 mm	11'7"	3,520 mm
Drifter	Model	HD818		HD818		HD822		HD828S		HD828		HD836	
	Weight	445 lb	202 kg	445 lb	202 kg	533 lb	242 kg	597 lb	271 kg	597 lb	271 kg	772 lb	350 kg
	Length	3'7"	1,100 mm	3'7"	1,100 mm	3'8"	1,130 mm	3'10"	1,158 mm	3'9"	1,148 mm	3'10"	1,171 mm
	Width	1'2"	352 mm	1'2"	352 mm	1'2"	373 mm	1'3"	387.4 mm	1'3"	387 mm	1'4"	418 mm
	Height	0'11"	275 mm	0'11"	275 mm	1'1"	328 mm	1'1"	327.5 mm	1'1"	328 mm	1'3"	375 mm
Undercarriage	Number of Blows	2,800 - 3,400 bpm		2,800 - 3,400 bpm		2,700 - 3,300 bpm		2,500 - 3,000 bpm		2,700 - 3,300 bpm		2,600 - 3,100 bpm	
	Rotating Speed	0 - 200 rpm	0 - 200 min <sup>-1</sup>	0 - 200 rpm	0 - 200 min <sup>-1</sup>	0 - 190 rpm	0 - 190 min <sup>-1</sup>	0 - 190 rpm	0 - 190 min <sup>-1</sup>	0 - 190 rpm	0 - 190 min <sup>-1</sup>	0 - 120 rpm	0 - 120 min <sup>-1</sup>
	Track Length	10'0"	3,060 mm	10'4"	3,159 mm	10'4"	3,159 mm	11'8"	3,545 mm	11'8"	3,690 mm	12'1"	3,690 mm
	Track Length on Ground	7'11"	2,425 mm	7'10"	2,395 mm	7'10"	2,395 mm	9'1"	2,780 mm	9'5"	2,880 mm	9'5"	2,880 mm
	Track Width	0'12"	300 mm	1'1"	330 mm	1'1"	330 mm	1'1"	330 mm	1'1"	330 mm	1'1"	330 mm
	Ground Contact Pressure *3	10.8 psi	74.3 kPa	11.8 psi	81.6 kPa	11.2 psi	77.5 kPa	13.0 psi	89.8 kPa	14.8 psi	101.8 kPa	14.8 psi	101.8 kPa
	Ground Clearance	1'10"	550 mm	1'11"	585 mm	1'11"	585 mm	1'7"	470 mm	1'10"	560 mm	1'10"	560 mm
	Frame Oscillation Angle	±10°		±7.6°		±7.6°		±8.5°		±7.5°		±7.5°	
	Tramming Speed	0 - 2.2 mph	0 - 3.5 km/h	0 - 2.2 mph	0 - 3.5 km/h	0 - 2.2 mph	0 - 3.5 km/h	0 - 2.3 mph	0 - 3.7 km/h	0 - 2.0 mph	0 - 3.3 km/h	0 - 2.0 mph	0 - 3.3 km/h
	Gradeability	57.7% (30°)		57.7% (30°)		57.7% (30°)		57.7% (30°)		57.4% (30°)		57.4% (30°)	
Maximum Traction Force	16,636 lb-force	74 kN	19,783 lb-force	88 kN	19,783 lb-force	88 kN	22,144 lb-force	98.5 kN	28,551 lb-force	127 kN	28,551 lb-force	127 kN	
Engine	Make & Model	Cummins® QS86.7 (Tier4 Final, Stage IV)		Cummins® QS86.7 (Tier4 Final, Stage IV)		Cummins® QS86.7 (Tier4 Final, Stage IV)		Cummins® / B6.7 (Final/Stage V)		CAT® / C9.3B (Tier4Final, Stage V)		CAT® / C9.3B (Tier4Final, Stage V)	
	Type	Diesel, Water-Cooled, 6 Cylinders		Diesel, Water-Cooled, 6 Cylinders		Diesel, Water-Cooled, 6 Cylinders		Diesel, Water-Cooled, 6 Cylinders		Diesel, Water-Cooled, 6 Cylinders		Diesel, Water-Cooled, 6 Cylinders	
	Piston Displacement	408.9 cu in	6.7 L	408.9 cu in	6.7 L	408.9 cu in	6.7 L	408.9 cu in	6.7 L	567.5 cu in	9.3 L	567.5 cu in	9.3 L
	Power Output	225.3 hp / 2,200 rpm	168 kW / 2,200 min <sup>-1</sup>	225 hp / 2,200 rpm	168 kW / 2,200 min <sup>-1</sup>	225 hp / 2,200 rpm	168 kW / 2,200 min <sup>-1</sup>	260 hp / 2,500 rpm	194 kW / 2,500 min <sup>-1</sup>	375 hp / 2,200 rpm	280 kW / 2,200 min <sup>-1</sup>	375 hp / 2,200 rpm	280 kW / 2,200 min <sup>-1</sup>
	Fuel Capacity	84.5 gal	320 L	84 gal	320 L	84 gal	320 L	112.3 gal	425 L	158.5 gal	600 L	158.5 gal	600 L
	DEF Capacity	5.0 gal	19 L	5.0 gal	19 L	5.0 gal	19 L	15 gal	56.8 L	11.8 gal	44.7 L	11.8 gal	44.7 L
Hydraulic Equipment	Variable Displacement Pump	PV Pump x2		PV Pump x2		PV Pump x2		PV Pump x2		PV Pump x2		PV Pump x2	
	Fixed Displacement Pump	Gear Pump x3		Gear Pump x3		Gear Pump x3		Gear Pump x3		Gear Pump x3		Gear Pump x3	
	Drive Motor	Hydraulic Motor with Reduction Gear		Hydraulic Motor with Reduction Gear		Hydraulic Motor with Reduction Gear		Hydraulic Motor with Reduction Gear		-		-	
	Hydraulic Oil Reservoir Capacity	44.9 gal	170 L	45 gal	170 L	45 gal	170 L	56.8 gal	215 L	63.4 gal	240 L	63.4 gal	240 L
Boom	Model	JF326		JF326		JF326		JE326		JE326-134		JE326-134	
	Type	Extension		Extension		Extension		Extension Boom		Extension Boom		Extension Boom	
	Boom Lifting Angle (Up / Down)	45° / 15°		45° / 15°		45° / 15°		41° / 20°		41° / 20°		41° / 20°	
	Boom Swing Angle (Right / Left)	37° / 43°		30° / 4°		30° / 30°		32° / 5°		32° / 0°		32° / 0°	
	Boom Slide Length	4'11"	1,500 mm	3'11"	1,200 mm	3'11"	1,200 mm	2'11"	900 mm	1'12"	600 mm	1'12"	600 mm
	Guide Rotary Angle	-		-		-		-		-		-	

# HCR SPECIFICATIONS

Model	HCR900-ESV		HCR1100-ED		HCR1100-ER		HCR190-E5		HCR110 WITH HD828 DRIFTER		HCR110 WITH HD836 DRIFTER		
	US Standard	Metric	US Standard	Metric	US Standard	Metric	US Standard	Metric	US Standard	Metric	US Standard	Metric	
Guide Shell	Model	GH831		GH831		GH831		GH832		GH832-33		GH832-33	
	Overall Length	25'3"	7,685 mm	25'7"	7,845 mm	26'0"	7,925 mm	28'7"	8,700 mm	28'7"	8,700 mm	28'7"	8,700 mm
	Feed Length	14'8"	4,480 mm	15'5"	4,704 mm	15'8"	4,781 mm	For 12': 15'1" For 14': 17'2"	For 3,660 mm: 4,595 mm For 4,265 mm: 5,225 mm	For 12': 15'1" For 14': 17'2"	For 3,660 mm: 4,595 mm For 4,265 mm: 5,225 mm	17'2"	5,225 mm
	Feed Type	Hydraulic Motor Driven Chain		Hydraulic Motor Driven Chain		Hydraulic Motor Driven Chain		Hydraulic Motor Driven Chain		Hydraulic Motor Driven Chain		Hydraulic Motor Driven Chain	
	Guide Slide Length	3'11"	1,200 mm	3'11"	1,200 mm	3'11"	1,200 mm	4'11"	1,500 mm	4'11"	1,500 mm	4'11"	1,500 mm
	Guide Swing Angle (Right / Left)	40° / 40°		30° / 90°		30° / 90°		25° / 90°		25° / 90°		25° / 90°	
	Guide Tilt Angle	180°		180°		180°		170°		170°		170°	
	Maximum Pulling Force	6,407 lb-force	28.5 kN	5,508 lb-force	24.5 kN	7,060 lb-force	31.4 kN	7,644 lb-force	34 kN	7,644 lb-force	34 kN	7,644 lb-force	34 kN
Compressor	Make & Model	AIRMAN PDS265-S37B		AIRMAN PDS265-S37B		AIRMAN PDS265-S37C		AIRMAN PDS265-S37F		AIRMAN / PDSF290-S16		AIRMAN / PDSF290-S16	
	Type	1-Stage Screw Compressor		1-Stage Screw Compressor		1-Stage Screw Compressor		1-Stage Screw Compressor		1-Stage Screw Compressor		1-Stage Screw Compressor	
	Discharge Airflow	215 cfm	6.1 m³/min	215 cfm	6.1 m³/min	275 cfm	7.8 m³/min	353 cfm	10.0 m³/min	477 cfm	13.5 m³/min	477 cfm	13.5 m³/min
Dust Collector	Discharge Pressure	149 psi	1.03 MPa	149 psi	1.03 MPa	149 psi	1.03 MPa	149 psi	1.03 MPa	149 psi	1.03 MPa	149 psi	1.03 MPa
	Model	A844-221		A884-221		A844		A885-44		A885-44		A885-44	
	Suction Capacity	706 cfm	20 m³/min	706 cfm	20 m³/min	918 cfm	26 m³/min	1,413 cfm	40 m³/min	1,413 cfm	40 m³/min	1,413 cfm	40 m³/min
	Number of Filter Elements	4		4		5		6		6		6	
	Dust Removal System	Automatic Air Pulse Jet		Automatic Air Pulse Jet		Automatic Air Pulse Jet		Automatic Air Pulse Jet		Automatic Air Pulse Jet		Automatic Air Pulse Jet	
Rod Arrangement	Suction Cap	Slide Type		Slide Type		Slide Type		Slide Type		Slide Type		Slide Type	
	Model	-		GR801		GR801		GR803		GR803-31		GR803-31	
	Type	Rack		Rod Changer		Rod Changer		Rod Changer		Rod Changer		Rod Changer	
	Number of Rods	4 + 1 (Starter Rod)		5		5 (For T38 & T45) / 4 (For T51)		7 (For 12') / 6 (For 14')		7 (For T51)		7 (For GT60) or 6 (For GT60-TUBE)	
	Rod Diameter	1.3", 1.5", 1.8"	32 mm, 38 mm, 45 mm	1.3", 1.5", 1.8"	32 mm, 38 mm, 45 mm	1.5", 1.8", 2.0"	38 mm, 45 mm, 51 mm	1.8", 2.0"	45 mm, 51 mm	2.0"	51 mm	2.36" / 3.43"	60 mm / 87 mm
	Number of Control Levers	-		1		1		1		1		1	
Bit and Rod	Bit Range	2.5" - 3.5"	64 mm - 89 mm	2.5" - 3.5"	64 mm - 89 mm	2.5" - 4"	64 mm - 102 mm	3.0" - 5.0"	76 mm - 127 mm	4.0" - 5.0"	102 - 127 mm	4.0" - 5.5"	102 - 140 mm
	Rod Diameter	32H, 38R, 45R, (38H)		32H, 38R, 45R, (38H)		38R, 45R, 51R		T45 / T51		T51		GT60 / GT60-TUBE	
	Rod Length	10' or 12'	3,050 mm or 3,660 mm	10' or 12'	3,050 mm or 3,660 mm	10' or 12'	3,050 mm or 3,660 mm	12' / 14'	3,660 mm / 4,270 mm	12' / 14'	3,660 mm / 4,270 mm	14'	4,270 mm
	Starter Rod Length	14'	4,270 mm	13'	4,000 mm	13'	4,000 mm	14' (For 12') / 18' (For 14')	4,270 mm (For 3,660 mm) / 5,490 mm (For 4,270 mm)	14'	4,270 mm	18'	5,490 mm
Electrics	Battery	12V; 108 Ah/5hr		12V; 108 Ah/5hr		12V; 108 Ah/5hr		12V; 108 Ah/5hr		12V; 160Ah/5hr x2		12V; 160Ah/5hr x2	
	Light	24V; 70W x4		24V; 70W x4		24V; 70W x4		24V; 70W x4		24V; 70W x4		24V; 70W x4	
	Voltage	DC 24V		DC 24V		DC 24V		DC 24V		DC 24V		DC 24V	
Operating Environment	Working Temperature	5° - 113° F	-15° - 45°C	5° - 113° F	-15° - 45°C	5° - 113° F	-15° - 45°C	5° - 113° F	-15° - 45°C	5° - 113° F	-15° - 45°C	5° - 113° F	-15° - 45°C
	Maximum Altitude	9,843'	3,000 m	9,842'	3,000 m	9,843'	3,000 m	8,202'	2,500 m	8,202'	2,500 m	8,202'	2,500 m

\*1 "Overall Weight (A)" includes weights of fuel and oils (full).

\*2 "Overall Weight (B)" includes weight of "Overall Weight (A)", operator, rod and bit.

\*3 "Ground Contact Pressure" is calculated based on "Overall Weight (A)".

## Proven-Reliable – High Performing

### DCRL130 Down-the-Hole-Drill

The DCRL130 has established itself as a reliable, productive resource for drilling operations around the world. These drills have been proven in soft, medium and hard rock conditions with multiple end-users and applications providing deep holes from 3.5" to 6.5" at fast drilling rates with low maintenance requirements.

The cabs have been redesigned to provide operators maximum comfort with single-lever drilling controls, digital gauges, and superior views of drilling operation.

- ▶ Low-emission Tier IV Final Caterpillar® engine offers low fuel consumption at 456hp and meets US Tier IV exhaust emissions regulations.
- ▶ Hoses and wiring are placed in a compact and efficient routing design for more protection, less wear and are easily replaced.
- ▶ Drill rod changer equipped with electronic sensors that speeds up rod addition and extraction.
- ▶ Heavy-duty undercarriage with low center of gravity – featuring a pentagonal section design to reduce dirt build-up and track wear – ensures strength, durability and stability.



# DCRL130





## Maximize Operator Performance with the Ultimate in Ergonomic Cab Design

When it comes to ergonomically-friendly cabs, Furukawa offers various options to minimize operator fatigue. Cabs are 43" wide (W1,100 mm) with ROPS/FOPS. In addition, all cabs are air-conditioned and continuously pressurized with filtered air to maintain a comfortable operating environment. Other features include:

- Single-lever drilling control for easy operation.
- Finger-touch levers for smooth traming control.
- Large windows maximize operator visibility.
- All-in-One display allows operator to monitor machine functions and angle indicator for quick and easy drilling alignment while remaining focused on the drilling.
- Walk-around ground level maintenance provides fast, easy upkeep or repair.
- Rubber-mounted engine frame isolates cab from engine vibrations.
- Bluetooth Player/Sirius XM Radio is standard.

## Combining Performance and Economy

- Angle indicator for quick and easy drilling alignment.
- Drill hole diameter 3.5" - 6.5".
- Reliable dust control system increases suction capacity and provides effective pre-cleaning to reduce the escape of drilling dust. An optional dust suppression system is available for difficult drilling conditions.
- Advanced rotary rod changer allows easy drill rod changes.
- High-output compressor increases flushing air, provides faster drilling and decreases bit wear.



# DCRL130

# Dimensions

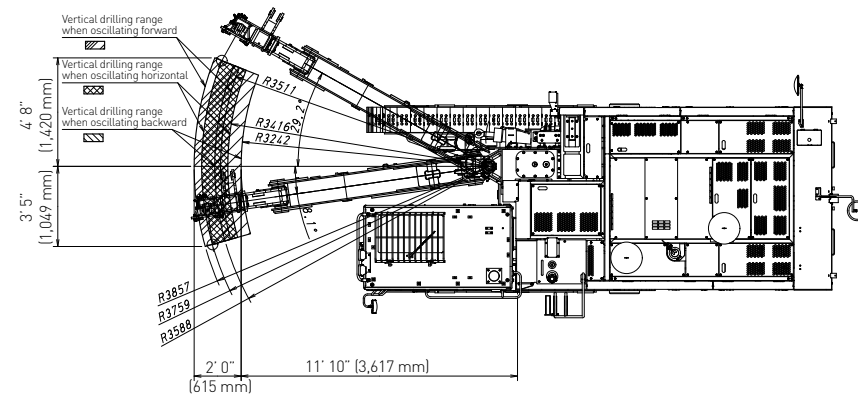
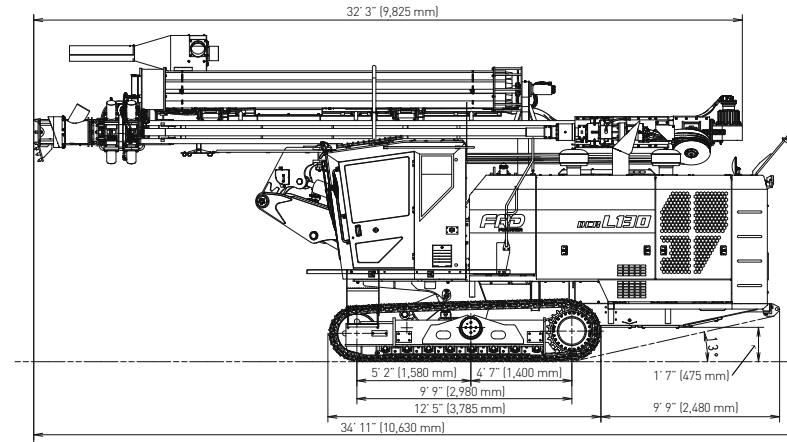
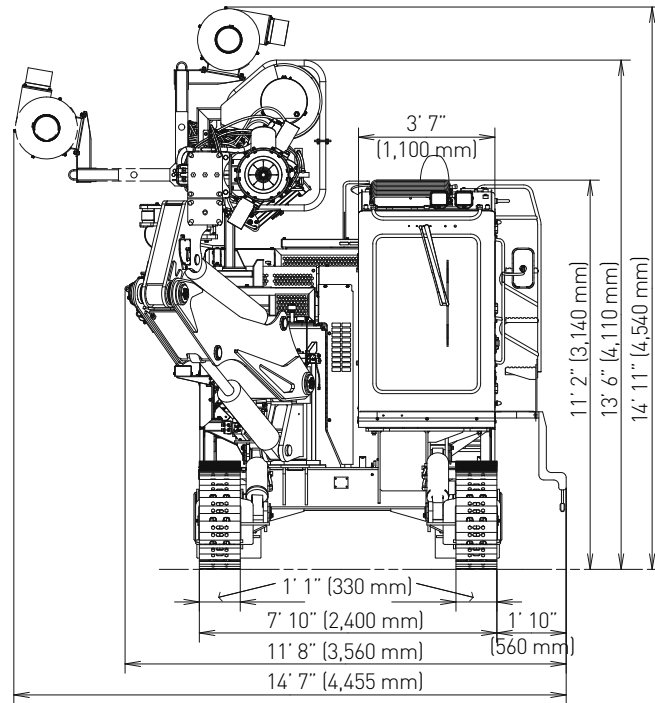

Model		DCRL130	
		US Standard	Metric
Dimensions and Weight	Overall Weight (A) *1	52,029 lb	23,600 kg
	Overall Weight (B) *2	54,675 lb	24,800 kg
	Overall Length	34'11"	10,630 mm
	Shipping Length	36'6"	11,125 mm
	Overall Width	14'7"	4,455 mm
	Shipping Width	8'10"	2,700 mm
	Overall Height	14'11"	4,540 mm
	Shipping Height	11'6"	3,500 mm
Drill Motor	Model	DOWMAX/ME350	
	Reduction Ratio	1 : 3.071	
	Maximum Torque	3,098 lb-force-ft	4.2 KN-m
	Rotating Speed	0 - 120 rpm	0 - 120 rpm
	Bit Range	3.5 - 6.5 in	89 - 165 mm
Undercarriage	Track Length	12'5"	3,785 mm
	Track Length on Ground	9'9"	2,980 mm
	Track Width	1'1"	330 mm
	Ground Contact Pressure *5	17.1 psi	118 kPa
	Ground Clearance	1'7"	475 mm
	Frame Oscillation Angle	±7.5°	
	Tramming Speed	0 - 2.2 mph	0 - 3.5 km/h
	Gradeability	46.6% (25°)	
Maximum Traction Force	35,969 lb-force	160 kN	
Engine	Make & Model	CAT® C13 (Tier4 Final)	
	Type	Diesel, Water-Cooled, 6 Cylinders	
	Piston Displacement	3.3 gal	12.5 L
	Power Output	456 hp / 2,000 rpm	340 kW / 2,000 min <sup>-1</sup>
	Fuel Capacity	192.8 gal	730 L
	DEF Capacity	18.5 gal	70 L
Hydraulic Equipment	Variable Displacement Pump	PV Pump x2	
	Fixed Displacement Pump	Gear Pump x3	
	Drive Motor	Hydraulic Motor with Reduction Gear	
	Hydraulic Oil Reservoir Capacity	74 gal	280 L
Boom	Model	JF325	
	Type	Fixed	
	Boom Lifting Angle (Up / Down)	50.5° / 13.9°	
	Boom Swing Angle (Right / Left)	30° / 8°	

## Note:

- \*1 "Overall Weight (A)" includes weights of fuel and oils (full).
- \*2 "Overall Weight (B)" includes weight of "Overall Weight (A)", operator, rod and bit.
- \*3 "Shipping Height (A)" includes dimensions with disassembling guide rest.
- \*4 "Shipping Height (B)" includes dimensions with disassembling guide rest and rear magazine plate.
- \*5 "Ground Contact Pressure" is calculated based on "Overall Weight (A)".

Model		DCRL130	
		US Standard	Metric
Guide Shell	Model	GH834	
	Overall Length	32'6"	9,910 mm
	Feed Length	18'8"	5,694 mm
	Feed Type	Hydraulic Motor Driven Chain	
	Guide Slide Length	4'11"	1,500 mm
	Guide Swing Angle (Right / Left)	16° / 90°	
	Guide Tilt Angle	120°	
	Maximum Pulling Force	6,744 lb-force	30 kN
Compressor	Make & Model	AIRMAN PDSK900-S20	
	Type	2-Stage Screw Compressor	
	Discharge Airflow 1	953 cfm	27.0 m³/min
	Discharge Airflow 2	858 cfm	24.3 m³/min
Discharge Pressure	334 psi (When 2,000 rpm/min -1) / 363 psi (When 1,800 rpm/min -1) / 2.3 MPa (When 2,000 rpm/min -1) / 2.5 MPa (When 1,800 rpm/min -1)		
Dust Collector	Model	A885	
	Suction Capacity	2,649 cfm	75 m³/min
	Number of Filter Elements	12	
	Dust Removal System	Automatic Air Pulse Jet	
Suction Cap	Slide Type		
Rod Changer	Model	GR803	
	Number of Rods	8	
	Rod Length	16'5"	5,000 mm
	Rod Diameter	3", 3.5", 4"	76 mm, 89 mm, 102 mm
	Number of Control Levers	1	
Electrics	Battery	12V x 2; 176Ah/5hr	
	Light	24V; 70W x4	
	Voltage	DC 24V	
Operating Environment	Working Temperature	5° - 113° F	-15° - 45° C
	Maximum Altitude	6,562'	2,000 m

# DCR SPECIFICATIONS



Options		HCR900-ESV	HCR1100-ED	HCR1100-ER	HCRL90	HCRL110	DCRL130
Water/Dust Suppression System	35 gal	●	●	●	●	●	—
	70 gal	●	●	●	●	●	●
Remote Control		—	—	●	—	—	—
2D Angle Indicator		●	●	●	●	●	●
3D Angle Indicator		—	●	—	●	●	●
All-in-One 3D Angle Indicator		—	—	—	●	●	—
with side/rear camera		—	—	—	●	●	Standard
Rear & Side View Camera with Separate Monitor		—	●	—	●	●	—
Rear Bumper		●	●	●	●	●	●
Cold Weather Kit (Esper, Webasto)		●	●	●	●	●	●
Hand Rail		—	—	—	●	●	●
Central Greaser		—	●	—	●	●	●

● option  
 — not available



Water/Dust Suppression System HCR



Rear Bumper



Rear Camera



3D Angle Indicator



2D Angle Indicator

A variety of options are available to fit the Furukawa crawler drill. Contact your local dealer for more information.

# OPTIONS

## Pneumatic Crawler Drill

### Crawler Assembly

The crawler uses parts designed and time tested by Furukawa. These include the track-link crawler chains and track rollers. The ruggedly constructed crawler demonstrates effortless maneuverability on rough ground and is designed for easy maintenance.

### Exceptional Stability on Soft Ground

Shoe plate width is 11.8 inches ( 300 mm ), which is wider than that of any other competitive model. Low ground-contact pressure as well as a low center of gravity further ensure dependable traction on soft ground and maximum stability during the drilling operation.

### Lifetime Floating Seals for Minimum Maintenance

Lifetime floating seals are used in the front idlers and track rollers, making lubrication unnecessary for an extended period of time. Track guards prevent the shoe links from misalignment and also protect and help extend the life of the links.

### Convenient Crawler-Tension Adjustment

Crawler tension may be hydraulically adjusted with the utmost ease by using a grease gun.

### Effortless Mobility on Rough Terrain

Powerful 12HP air motors and a hydraulic oscillating system permit ample mobility and traction even on rough terrain. The motors provide adequate power to climb slopes while towing a compressor.

### Direct Motor-Connected Final Drive

The final drive is directly connected to the air motor to minimize power loss and ensure drive efficiency.

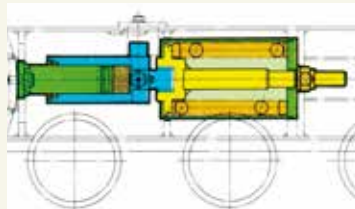

*Pneumatic Drive Motor*



*Ample Clearance*

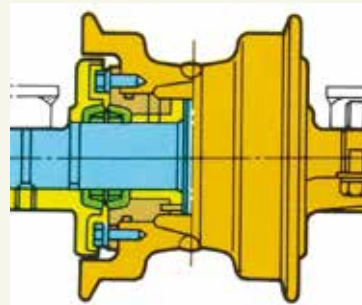

# PCR200

### Performance of PD200 drifter

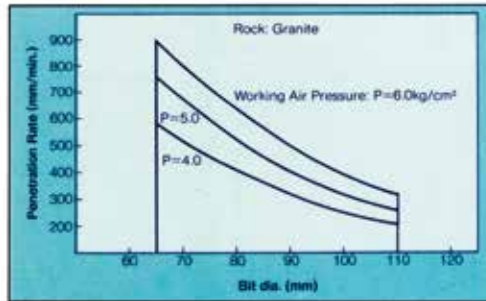

### Performance data of long hole drilling

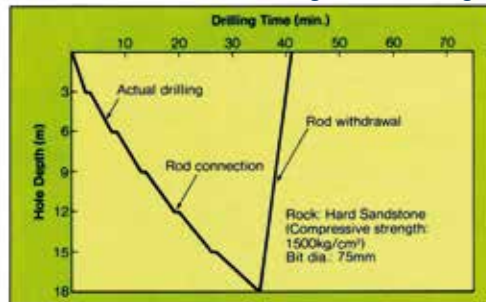

### Performance data of long hole drilling

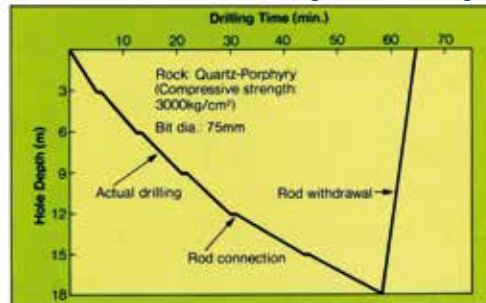

## Dimensions

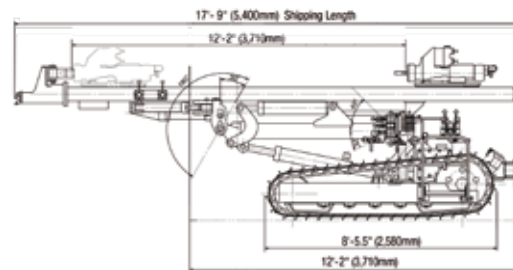
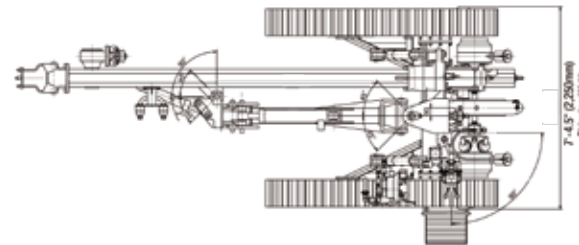
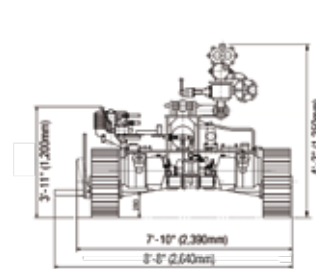

Model	PCR200		
	US Standard	Metric	
<b>Dimensions and Weight</b>	Weight	11,020 lb	5,000 kg
	Overall Length	17'9"	5,400 mm
	Feed Travel	12'	3,710 mm
	Track Length	8'5"	2,580 mm
	Length of Ground Contact	6'1"	1,885 mm
	Tow Hitch Height	1'9.5"	550 mm
	Overall Width	7'9.5"	2,390 mm
	Track Width	7'3"	2,200 mm
	Width of Grousers	1'	300 mm
	Overall Height (Boom lowered)	4'2"	1,250 mm
<b>Crawler Traction</b>	Ground Pressure	.45 kg/cm <sup>2</sup>	
	Traveling Speed (Towing a compressor on level ground)	1.9 mph	3.2 km/h
	Gradeability	22°	
	Oscillating Angle	15°	
	Traction Air Motor (Model MR13, Piston-Type)	8.8 kW	
<b>Guide Shell</b>	Max. Horizontal Drill Height	10'	3,050 mm
	Guide Slide Travel	3'11"	1,200 mm
	Air Feed Motor (Model MC2)	4 kW	
	Steel Change	10'	3,050 mm
<b>Hydraulic Units</b>	Boom Length	6'6"	2,000 mm
	Boom Lift (Up / Down)	45° / 25°	
	Boom Swing (Right / Left)	45° / 45°	
	Guide Swing (Right / Left) (95° right, 15° left with pin change)	50° / 50°	
	Guide Tilt	180°	
	Power Pump (Model MP12)	4 kW	
<b>Drifter (Model PD200)</b>	Weight without Shank rod	396 lb	180 kg
	Length without shank Rod	3'3.5"	1,020 mm
	Cylinder Diameter	5.1"	130 mm
	Piston Stroke	3.1"	80 mm
	Air Consumption	565 cfm	16 cbm
	Blows/min	~1,600	
Main Air Hose Connection	2"	50 mm	

# FRD Headquarters

Structured for success with nearly 85,000 square feet.



**CORPORATE HEADQUARTERS**  
**Furukawa Rock Drill USA**  
 805 Lake Street, Kent, Ohio 44240-0017  
 Phone 330-673-8419  
[www.frdusa.com](http://www.frdusa.com)

# SERVICE & SUPPORT

## Local Service and Support

FRD USA supplies a range of products that provide value and dependability for every job. All of our drills and components are backed by a dedicated distributor network focused on meeting your needs.

We carefully partner with distributors for their professional competence, market coverage, dedication to quality and stellar work ethic. Our distributors receive intense training on all machines, systems and support services. They also actively exchange experiences, to provide the best and most current solutions to customers.

### NEVADA BRANCH OFFICE West Coast Sales & Service Facility

7730 Security Circle, Reno, NV 89506  
Phone 775-260-7366  
[www.frdusa.com](http://www.frdusa.com)



# SERVICE & SUPPORT

High-performance drilling options. More productive. Less maintenance.



**SOUTH CAROLINA BRANCH OFFICE**  
**Southeast Sales & Service Facility**  
155 Dexter Road, Spartanburg, SC 29303  
Phone 864-541-0125  
[www.frdusa.com](http://www.frdusa.com)

# SERVICE & SUPPORT

## Breaker Attachment Division Formerly Known as Kent

With over 55 years of experience, FRD USA Attachment Division offers a one-stop shop for attachments that cover almost any demolition job. What's more – built to last – FRD attachments meet the everyday need for reliability and high-performance.

FRD USA is backed by the resources of Furukawa Corporation – one of Japan's largest and most diverse corporations. Today – a multi-billion dollar company – Furukawa provides FRD USA with the engineering and manufacturing support of a global company whose roots are based in mining and construction.

FRD's complete line of products maximizes the versatility of your equipment, while minimizing your overhead costs. With more than 30 different attachments, FRD USA helps you get any job done right.



## Encore® Recertification Program

### Protect Your Investment

Overlooking routine maintenance on any hydraulic breaker can be a costly mistake. Regularly maintained breakers upgrade your initial tool investment and decrease the likelihood of breaker failure during operation or rental. Upgraded equipment will increase utilization, generating more revenue.

### Maintenance As Easy As I, II Or III

The new **Encore® Recertification Program** from FRD USA shifts the burden and expense of routine breaker maintenance onto factory-trained FRD technicians and away from overworked, understaffed service departments.

Designed to extend the life of your FRD hydraulic breaker, the unique Encore Recertification Program offers three distinct service levels, each incorporating various maintenance options. From routine tool inspection to complete overhaul, you choose the level that best suits your needs.

### Additional Program Benefits

The Encore Recertification Program offers dealers and their customers even more flexibility with these additional benefits:

- ▶ Purchase one program tier, but retain the option to upgrade to the next tier while paying only for the level of service that is performed.
- ▶ Purchase any additional parts required for proper repair – without additional installation charges.

### Minimal Investment...Maximum Performance

The Encore Recertification Program is exclusive to FRD USA dealers and their customers at a minimal cost. For more details on program procedures, contact FRD USA at 800-275-2282.



# BREAKER ATTACHMENT DIVISION

High-performance drilling options. More productivity. Less maintenance.



HIGH-PERFORMANCE DRILLING OPTIONS. MORE PRODUCTIVITY. LESS MAINTENANCE.

**DISTRIBUTOR:**



**CORPORATE HEADQUARTERS**  
**Furukawa Rock Drill USA**  
805 Lake Street, Kent, Ohio 44240-0017  
Phone 330-673-8419  
[www.frdusa.com](http://www.frdusa.com)

**SOUTH CAROLINA BRANCH OFFICE**  
**Southeast Sales & Service Facility**  
155 Dexter Road, Spartanburg, SC 29303  
Phone 864-541-0125  
[www.frdusa.com](http://www.frdusa.com)

**NEVADA BRANCH OFFICE**  
**West Coast Sales & Service Facility**  
7730 Security Circle, Reno, NV 89506  
Phone 775-260-7366  
[www.frdusa.com](http://www.frdusa.com)

Scan this code for more information  
on Furukawa Rock Drills.



FRD-RD-2023