

KENT HYDRA RAMS 10GII & 15GII

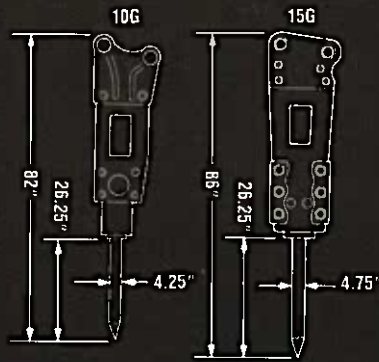

Kent 10G and 15G Hydra Rams deliver the productive punch needed to handle larger, more demanding jobs. Designed for large rubber-tired backhoes, excavators, and wheel loaders, these job-proven models are ideal for use on roads and bridges, rock, utility applications, and in quarries reducing oversize. Their unique valve design and piston configuration provide optimum impact energy transmission, while reducing impact reaction and shock to the carrier. A frequency blow adjuster enables the operator to use slow and heavy blows, or fast and lighter impact, to efficiently tackle varying job demands.

Features/Benefits

- Nitrogen charged back head for superior impact energy.
- Specially-designed piston for efficient transfer of energy to working steel.
- Blow frequency adjuster adapts tool and carrier to work conditions.
- Square breaker body encased by heavy-duty sideplates for optimum strength and rigidity.
- Standard working steel of your choice with mounting pins at no additional charge.
- Centralized arrangement of major parts for easy access and speedier maintenance.
- Pre-engineered installation kits to fit most carriers.

| | 10G | 15G |
|-------------------------------|--|--|
| Bracket Type | Top | Top |
| Weight | 1610 lbs. (730 kg) | 2880 lbs. (1306 kg) |
| Length | 82 in. (2083 mm) | 86 in. (2184 mm) |
| Blows/Minute (variable) | 400-900 | 400-900 |
| Impact Energy Class | 2000 ft/lbs (907 kg/m) | 3000 ft/lbs (1360 kg/m) |
| Oil Flow | 19-24 GPM (70-90 LPM) | 24-32 GPM (90-120 LPM) |
| Operating Pressure | 2000-2275 PSI (140-160 kg/cm ²) | 2150-2550 PSI (150-170 kg/cm ²) |
| Tool Dia. | 4.25 in. (105 mm) | 4.75 in. (120 mm) |
| Usable Working Steel | 26.25 in. (667 mm) | 26.25 in. (667 mm) |



711 Lake Street • Kent, Ohio 44240
216-673-5826 • Fax: 216-673-5824, Ext. 233
Toll Free: 1-800-527-2282 (East Coast) • 1-800-624-1616 (West Coast)

