



FURUKAWA ROCK DRILL USA

711 Lake Street Kent, Ohio 44240 U.S.A. Phone: 330.673.5826 Fax: 330.677.1616

Breaker/Attachment Division

SECTION VI

PARTS LIST

Fx15 Serial No. 1001 ~ & up

*Revised: September, 2010
Section VI - Page # 1*

Fx15 HYDRARAM **PARTS BREAKDOWN**

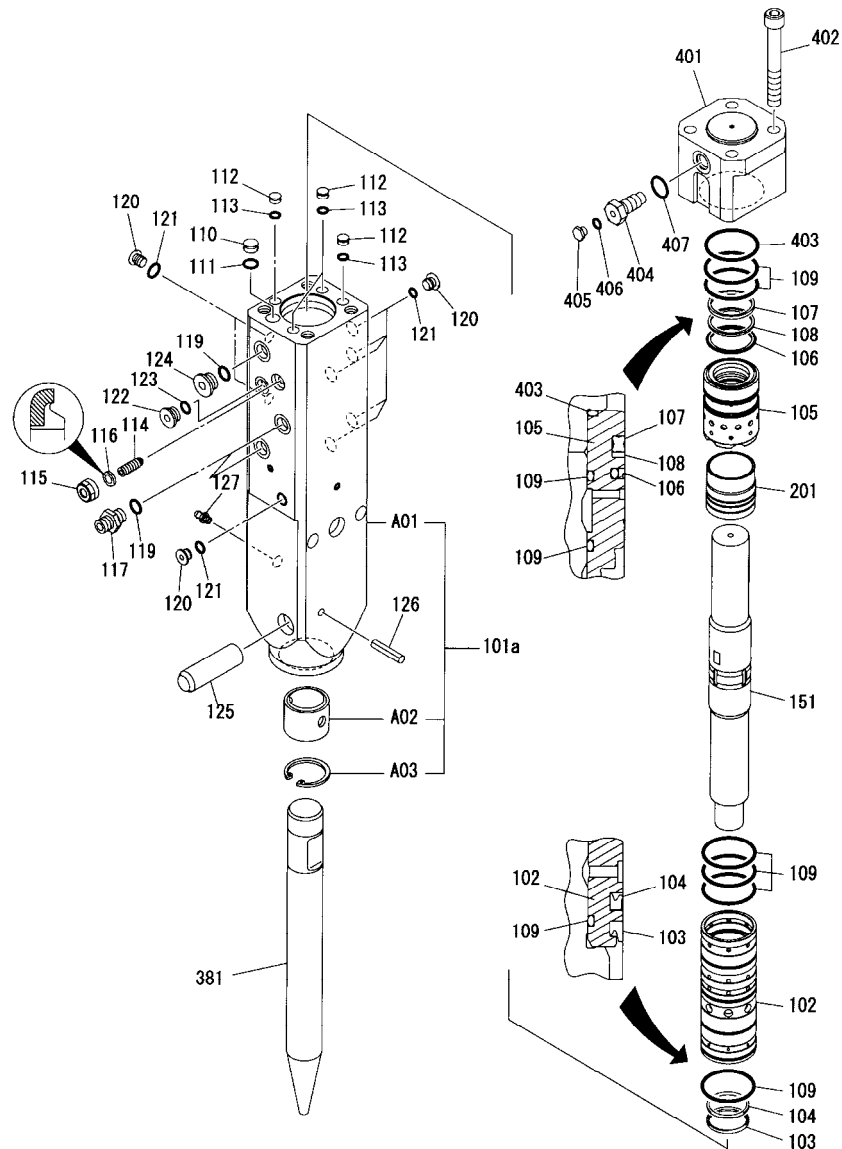



Fx15 HYDRARAM **PARTS LIST**

<u>ITEM</u>	<u>PART NUMBER</u>	<u>QTY</u>	<u>DESCRIPTION</u>	<u>ITEM</u>	<u>PART NUMBER</u>	<u>QTY</u>	<u>DESCRIPTION</u>
101a	002305100010	1	Cylinder Assy	123	16001100011	1	O-Ring [/S]
A01	N/A	[1]	Bare Cylinder	124	08489103000	1	GPF Plug
A02	12338	[1]	Front Bushing	125	F120206	2	Rod Pin
A03	12339	[1]	Snap Ring	126	15403708050	2	Spring Pin
102	002305100030	1	Cylinder Liner	127	17031200000	1	Grease Nipple
103	HB1R10106	1	Dust Seal [/S]	151	002305110010	1	Piston
104	HB1R10107	1	Packing [/S]	201	002305130011	1	Valve
105	002305100041	1	Seal Retainer	381	F125111	1	Blunt
106	002305100050	1	Step Seal [/S]	381	F125114	1	Chisel
107	002305100061	1	Quad Ring [/S]	381	F125115	1	Moil
108	002305100070	1	Back-Up Ring [/S]	401	002305300010	1	Back Head
109	16102100050	6	O-Ring [/S]	402	10203214120	4	Socket Bolt
110	HB2R10120	1	Plug [/S]	403	16102100050	1	O-Ring [/S]
111	16001110010	1	O-Ring [/S]	404	HB15G30103	1	Charge Valve
112	HB05R10122	4	Plug [/S]	405	HB20G30109	1	Plug
113	16001100009	4	O-Ring [/S]	406	16001100006	1	O-Ring [/S]
114	F410231	1	Adjuster	407	16001100018	1	O-Ring [/S]
115	F410233	1	Seal Nut	*	902305920010	/S	Seal Kit
116	HB1G10532	1	Seal Washer [/S]				
117	15763	2	Port Adapter				
119	16001100014	3	O-Ring [/S]				
120	08489101000	8	GPF Plug				
121	16001100008	8	O-Ring [/S]				
122	08489102000	1	GPF Plug				

() Bracketed quantities indicate items included with the prior assembly.
 [/S] Items marked Option /S are included in the 902305920010 Seal Kit

* (Not shown. Refer to Section VII for Seal Kit Details)

Fx15 HYDRARAM **STANDARD MOUNTING BRACKET**

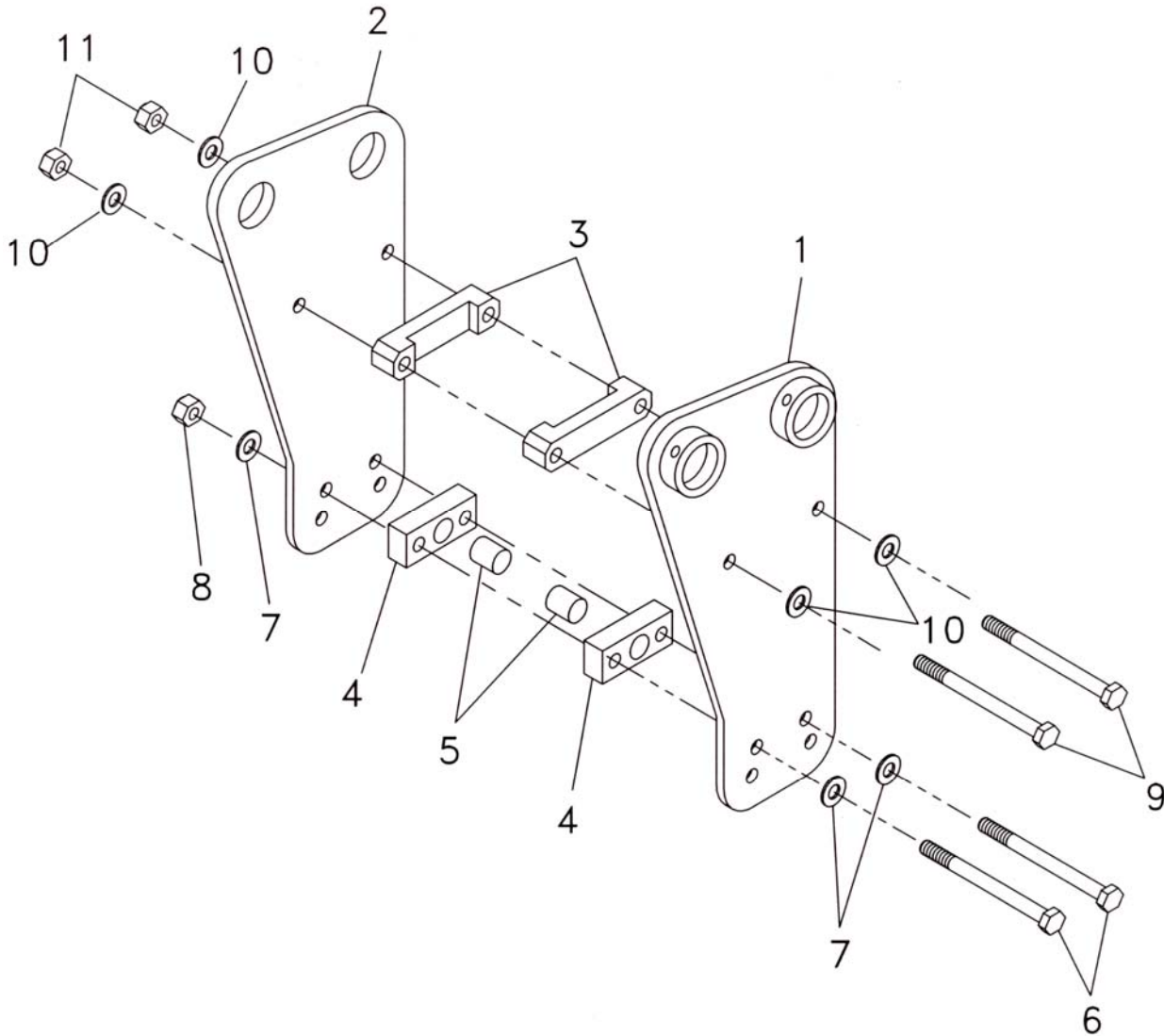



Fx15 HYDRARAM
STANDARD MOUNTING BRACKET

<i>ITEM</i>	<i>PART NUMBER</i>	<i>QUANTITY</i>	<i>DESCRIPTION</i>
1	FX15006	1	R.H. Side Plate
2	FX15007	1	L.H. Side Plate
3	FX15011	2	Set Plate "B"
4	FX15010	2	Set Plate "A"
5	FX15013	2	Set Pin
6	FX15012	2	5/8"-11 UNC X 8.00" HHCS, Gr. 5
7	7230	4	5/8" Flat Washer
8	6346	2	5/8"-11 Lock Nut
9	10193	2	3/4"-10 UNC X 8.00" HHCS, Gr. 5
10	7234	4	3/4" Flat Washer
11	10195	2	3/4"-10 Lock Nut



NOTES:



FURUKAWA ROCK DRILL USA

711 Lake Street Kent, Ohio 44240 U.S.A. Phone: 330.673.5826 Fax: 330.677.1616

Breaker/Attachment Division

MOUNTING PIN KIT FOR
FX15 HYDRARAM

Serial Number

Base Machine Make: _____

Base Machine Model: _____

Dipperstick Pin Diameter: _____

Link Pin Diameter: _____

Dipperstick Width: _____

Link Pin Width: _____

MOUNTING KIT PART NO: _____

Consisting of the following:

<i>ITEM</i>	<i>PART NUMBER</i>	<i>QUANTITY</i>	<i>DESCRIPTION</i>
1	_____	1	_____ Dia. Mounting Pin x _____ lg.
2	_____	1	_____ Dia. Mounting Pin x _____ lg.
3	_____	2	_____ Dia. Mounting Bushing x _____ lg.
4	_____	2	_____ Dia. Mounting Bushing x _____ lg.

SERVICE TOOL KIT

P/N BMX1590001

Furukawa Rock Drill USA includes a tool kit with every new hydraulic breaker. This tool kit contains many of the special tools and wrenches required to perform normal maintenance or repairs on the breaker. This is a basic tool kit, and is by no means complete or comprehensive, but it does contain some specialized tools, and wrench sizes not commonly found in the field. The following illustration depicts a typical tool kit and its contents:

