

SECTION VI

PARTS LIST

F70Qt Serial No. 1001 ~1061

*Revised: March, 2010
Section VI - Page # 1
F70-K102*

F70Qt HYDRARAM PARTS BREAKDOWN

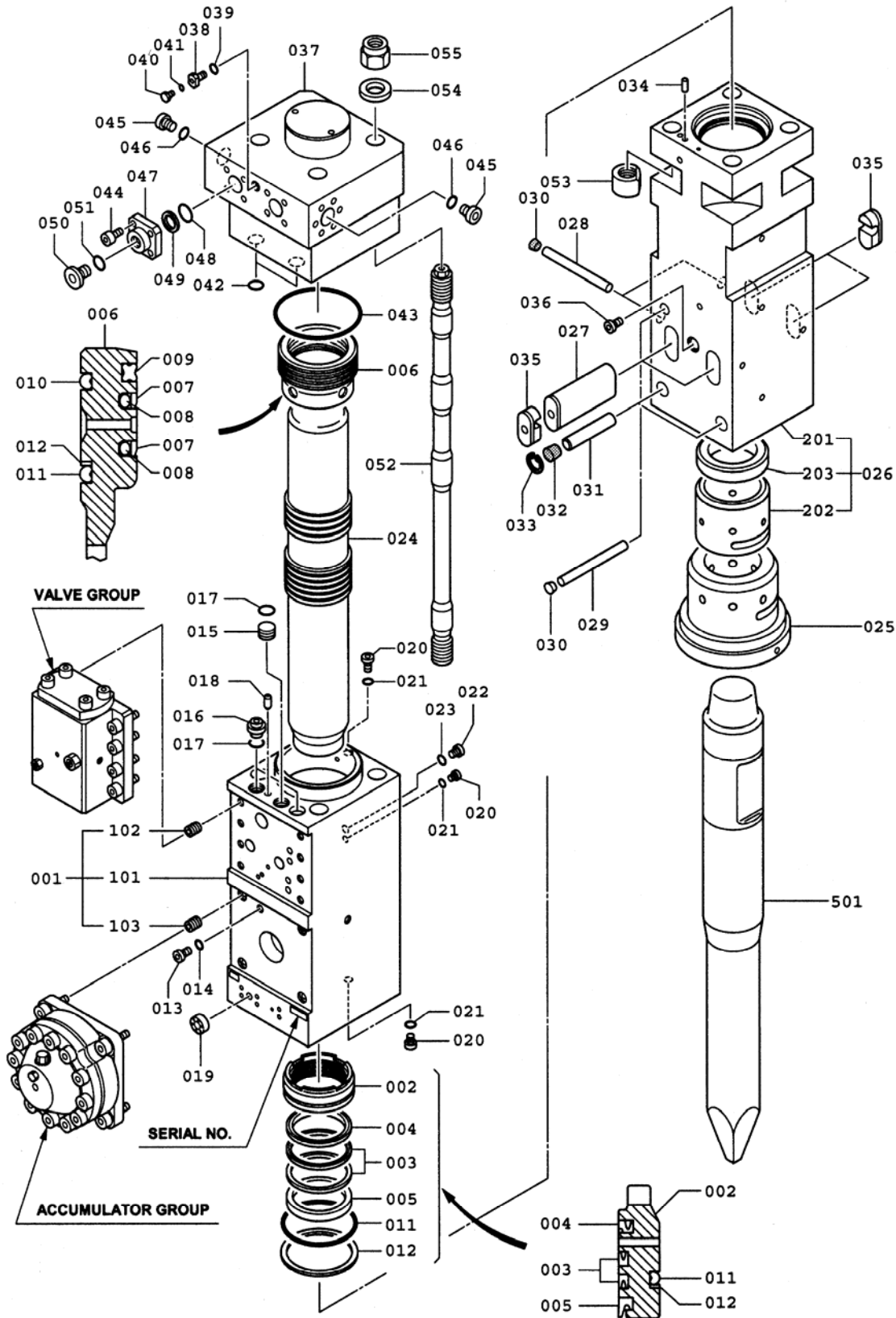

F70Qt HYDRARAM PARTS LIST



<u>ITEM</u>	<u>PART NUMBER</u>	<u>QTY</u>	<u>DESCRIPTION</u>	<u>ITEM</u>	<u>PART NUMBER</u>	<u>QTY</u>	<u>DESCRIPTION</u>
001	KF70-10101	1	Cylinder	030	KHB50G-20109	-	Rubber Plug [/SB]
101	KF70-10102	(1)	Cylinder, bare	031	KHB50G-20110	2	Fronthead Pin
102	KHB15G-10104	(8)	Heli-Sert Insert	032	KHB40G-20108	2	Rubber Plug [/SB]
103	KHB40G-10104	(4)	Heli-Sert Insert	033	K264020-00036	2	Snap Ring [/SB]
002	KF70-10106	1	Seal Retainer	034	K001300-20118	1	Knock Pin
003	KHB50G-10107	2	U-Packing [/SA]	035	KHB50G-20112	-	Dust Plug [/SB] ⊕
004	KF70-10108	1	Buffer Ring [/SA]	036	K084891-06000	1	GPF Plug
005	KHB50G-10110	1	Dust Seal [/SA]	037	KF70-30101	1	Backhead
006	KF70-10111	1	Seal Retainer	038	KHB15G-30103	1	Charging Valve
007	KHB50G-10112	2	Slide Packing [/SA]	039	K160011-00018	1	O-Ring [/SB]
008	KHB50G-10113	(2)	O-Ring [/SA]	040	KHB20G-30109	1	Plug
009	KF70-10114	1	Ring Seal [/SA]	041	K160011-00006	1	O-Ring [/SB]
010	KF70-10116	1	Delta Ring [/SA]	042	K160011-00040	2	O-Ring [/SA]
011	KF70-10216	2	D-Ring [/SA]	043	K160021-00260	1	O-Ring [/SB]
012	K262032-00220	2	Backup Ring [/SA]	044	K102033-14035	8	Socket Bolt □
013	K084891-02000	1	GPF Plug		For FRONT Mounted Hoses use:		
014	K160011-00011	1	O-Ring [/SA]	045	K084891-10000	2	GPF Plug □
015	KHB50G-10120	1	Plug [/SA]	046	K160011-00029	2	O-Ring [/SB] □
016	KHB50G-10121	2	Bushing [/SA]	047	K11439	2	Adapter Flange □
017	K160011-00040	3	O-Ring [/SA]	048	K12584	2	O-Ring □
018	K001300-20118	1	Knock Pin	049	K12585	2	Backup Ring □
019	KF45-20113	1	Check Valve [/SA]		For SIDE Mounted Hoses use:		
020	K084891-04000	3	GPF Plug	047	KHB40G-30302	2	Adapter Flange □
021	K160011-00018	3	O-Ring [/SA]	048	K161025-00045	2	O-Ring [/SB] □
022	K084891-06000	1	GPF Plug	049	K262022-00045	2	Backup Ring [/SB] □
023	K160011-00024	1	O-Ring [/SA]	050	K084891-12000	2	GPF Plug □
024	KF70-11101	1	Piston	051	K160011-00038	2	O-Ring [/SB] □
025	KF70-20101	1	Front Cover	052	KF70-36101	4	Through Bolt
026	KF70-20102	1	Fronthead	053	KF70-36102	4	Lower Nut
201	KF70-20103	1	Fronthead, Bare	054	KF70-36105	4	Washer
202	KF70-20104	1	Thrust Bushing	055	KF70-36106	4	Hexagon Nut
203	KF70-20105	1	Thrust Ring	501	KF70-25201	(1)	Blunt Tip
027	KHB50G-20106	2	Rod Pin (Retainer)	501	KF70-25203	(1)	Moil Point
028	KHB50G-20107	1	Stop Pin	501	KF70-25204	(1)	Chisel Bit
029	KHB50G-20111	1	Stop Pin	-	KF70-90001	1	Service Tool Kit

□ Note: See Section VI - Page # 12 in this section for Hose Configurations

⊕ Dust Plugs are not used in the QT Box Hammer version

() Bracketed quantities indicate items included with the prior assembly.

[/SA] Items marked Option /SA are included in the Cylinder Group Seal Kit KF7092011 (S/N 1001-1061)

[/SA] Items marked Option /SA are included in the Cylinder Group Seal Kit KF7092021 (S/N 1062 & Up)

[/SB] Items marked Option /SB are included in the Front-Backhead Group Seal Kit KF7092012

[/SC] Items marked Option /SC are included in the Valve-Accumulator Group Seal Kit KF7092013

CONTROL VALVE DETAIL
ANTI-IDLE BLOW
F70Qt HYDRARAM

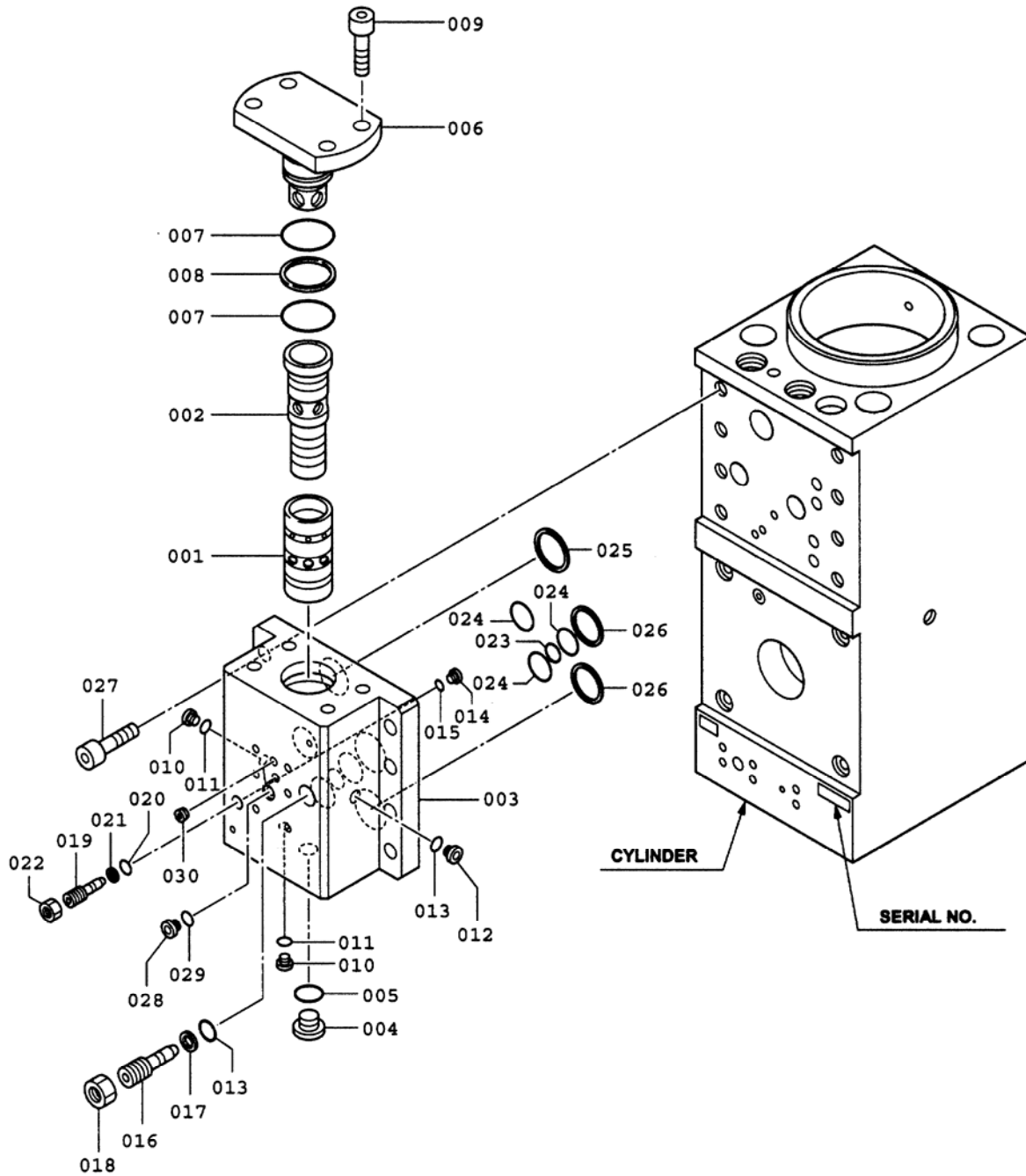

KF70-13002
CONTROL VALVE DETAIL
ANTI-IDLE BLOW
F70Qt HYDRARAM

<u>ITEM</u>	<u>PART NUMBER</u>	<u>QTY</u>	<u>DESCRIPTION</u>	<u>ITEM</u>	<u>PART NUMBER</u>	<u>QTY</u>	<u>DESCRIPTION</u>
001	KF70-13101	1	Valve	016	KHB50G-13110	1	Valve Adjuster
002	KF70-13102	1	Valve Plug	017	K262021-00018	1	Backup Ring [/SC]
003	KF70-13103	1	Valve Housing	018	K120133-27000	1	Hex Jam Nut
004	K084891-10000	1	GPF Plug	019	KF70-13111	1	Stroke Adjuster
005	K160011-00029	1	O-Ring [/SC]	020	K161011-00012	1	O-Ring [/SC]
006	KF70-13104	1	Housing Cover	021	K262021-00012	1	Backup Ring [/SC]
007	K161025-00075	2	O-Ring [/SC]	022	K120133-20000	1	Fine Thread Nut
008	K262032-00075	1	Backup Ring [/SC]	023	K161025-00030	1	O-Ring [/SC]
009	KHB20G-13106	4	Socket Bolt	024	K161025-00050	3	O-Ring [/SC]
010	K084891-02000	5	GPF Plug	025	KHB50G-13208	1	Face Seal [/SC]
011	K160011-00011	5	O-Ring [/SC]	026	KHB30G-13209	2	Face Seal [/SC]
012	K084891-04000	1	GPF Plug	027	K102032-24060	8	Socket Bolt
013	K160011-00018	2	O-Ring [/SC]	028	K084891-03000	1	GPF Plug
014	K084891-01000	2	GPF Plug	029	K160011-00014	1	O-Ring [/SC]
015	K160011-00008	2	O-Ring [/SC]	030	K166152-03000	1	Hollow Plug

() Bracketed quantities indicate items included with the prior assembly.
 [/SC] Items marked Option /SC are included in the Valve-Accumulator Group Seal Kit KF70-92013

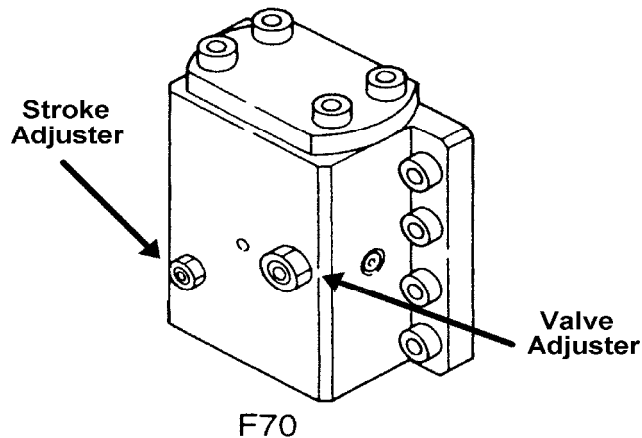

PORT BLOCK DETAIL **F70Qt HYDRARAM**

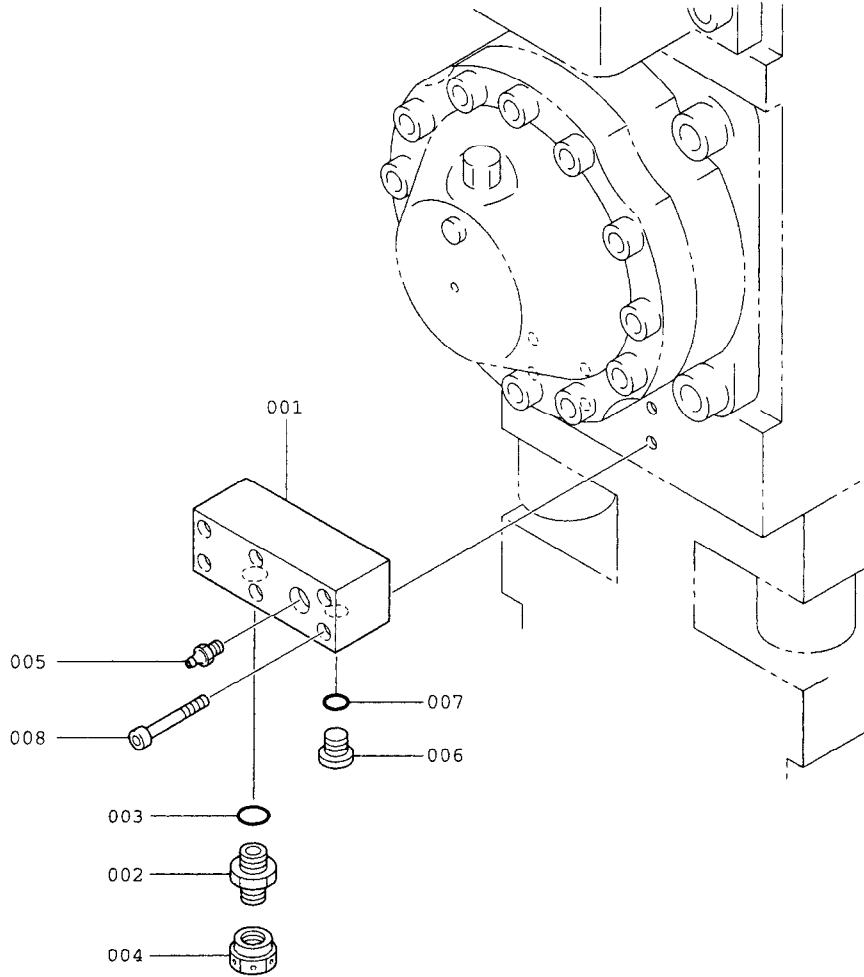

<u>ITEM</u>	<u>PART NUMBER</u>	<u>QTY</u>	<u>DESCRIPTION</u>	<u>ITEM</u>	<u>PART NUMBER</u>	<u>QTY</u>	<u>DESCRIPTION</u>
001	KF70-12101	1	Port Block	005	K001100-20123	1	Grease Fitting
002	K084869-06000	1	Filtered Connector	006	K084891-03000	1	GPF Plug
003	K160011-00029	1	O-Ring [/SA]	007	K160011-00014	1	O-Ring [/SA]
004	KF22-30113	1	Filter Cap	008	K102033-12070	6	Socket Bolt

[/SA] Items marked Option /SA are included in the Cylinder Group Seal Kit KF70-92011
 [/SA] Items marked Option /SA are included in the Cylinder Group Seal Kit KF70-92021

KHB50G-70002
ACCUMULATOR ASSEMBLY
F70Qt HYDRARAM

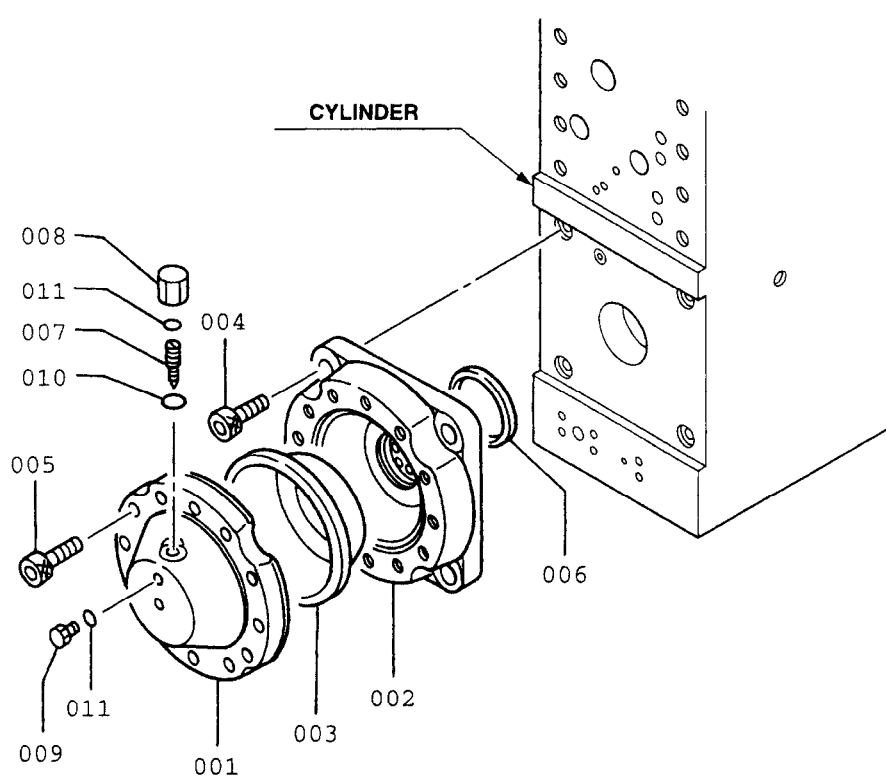

<u>ITEM</u>	<u>PART NUMBER</u>	<u>QTY</u>	<u>DESCRIPTION</u>	<u>ITEM</u>	<u>PART NUMBER</u>	<u>QTY</u>	<u>DESCRIPTION</u>
001	KHB50G-70101	1	Accumulator Cover	007	K007120-70134	1	Valve
002	KHB50G-70202	1	Accumulator Body	008	K007010-70029	1	Cap
003	KHB50G-70111	1	Diaphragm	009	K007010-70030	1	Plug
004	KHB50G-70115	4	Socket Bolt	010	K160011-00005	1	O-Ring [/SC]
005	KHB20G-13106	12	Socket Bolt	011	K160011-00014	2	O-Ring [/SC]
006	KHB100G-70219	1	Face Seal [/SC]				

[/SC] Items marked Option /SC are included in the Accumulator Group Seal Kit KF70-92013

KF70-92011 SEAL KIT (A) **CYLINDER & PORT BLOCK GROUP**

Line items refer to the drawing in section VI on page 2

<u>ITEM</u>	<u>PART NUMBER</u>	<u>QTY</u>	<u>DESCRIPTION</u>	<u>ITEM</u>	<u>PART NUMBER</u>	<u>QTY</u>	<u>DESCRIPTION</u>
003	KHB50G-10107	2	U-Packing	014	K160011-00011	1	O-Ring
004	KF70-10108	1	Buffer Ring	015	KHB50G-10120	1	Plug
005	KHB50G-10110	1	Dust Seal	016	KHB50G-10121	2	Bushing
007	KHB50G-10112	2	Slide Packing	017	K160011-00040	3	O-Ring
008	KHB50G-10113	(2)	O-Ring	019	KF45-20113	1	Check Valve
009	KF70-10114	1	Ring Seal	021	K160011-00018	3	O-Ring
010	KF70-10116	1	Delta Ring	023	K160011-00024	1	O-Ring
011	KF70-10216	2	D-Ring	042	K160011-00040	2	O-Ring
012	K262032-00220	2	Backup Ring				
Line items refer to the drawing in section VI on page 6							
003	K160011-00029	1	O-Ring	007	K160011-00014	1	O-Ring

KF70-92012 SEAL KIT (B) **FRONTHEAD & BACKHEAD GROUP**

Line items refer to the drawing in section VI on page 2

<u>ITEM</u>	<u>PART NUMBER</u>	<u>QTY</u>	<u>DESCRIPTION</u>	<u>ITEM</u>	<u>PART NUMBER</u>	<u>QTY</u>	<u>DESCRIPTION</u>
030	KHB50G-20109	3	Rubber Plug	043	K160021-00260	1	O-Ring
032	KHB40G-20108	2	Rubber Plug	046	K160011-00029	2	O-Ring
033	K264020-00036	2	Snap Ring	048	K161025-00045	2	O-Ring
035	KHB50G-20112	4	Dust Plug	049	K262022-00045	2	Backup Ring
039	K160011-00018	1	O-Ring	051	K160011-00038	2	O-Ring
041	K160011-00006	1	O-Ring				

KF70-92013 SEAL KIT (C) **VALVE & ACCUMULATOR GROUP**

Line items refer to the drawing in section VI on page 5

<u>ITEM</u>	<u>PART NUMBER</u>	<u>QTY</u>	<u>DESCRIPTION</u>	<u>ITEM</u>	<u>PART NUMBER</u>	<u>QTY</u>	<u>DESCRIPTION</u>
005	K160011-00029	1	O-Ring	020	K161011-00012	1	O-Ring
007	K161025-00075	2	O-Ring	021	K262021-00012	1	Backup Ring
008	K262032-00075	1	Backup Ring	023	K161025-00030	1	O-Ring
011	K160011-00011	5	O-Ring	024	K161025-00050	3	O-Ring
013	K160011-00018	2	O-Ring	025	KHB50G-13208	1	Face Seal
015	K160011-00008	2	O-Ring	026	KHB30G-13209	2	Face Seal
017	K262021-00018	1	Backup Ring				
Line items refer to the drawing in section VI on page 7							
006	KHB100G-70219	1	O-Ring	010	K160011-00005	1	O-Ring
011	K160011-00014	2	O-Ring				

T-BOX MOUNTING F70Qt HYDRARAM

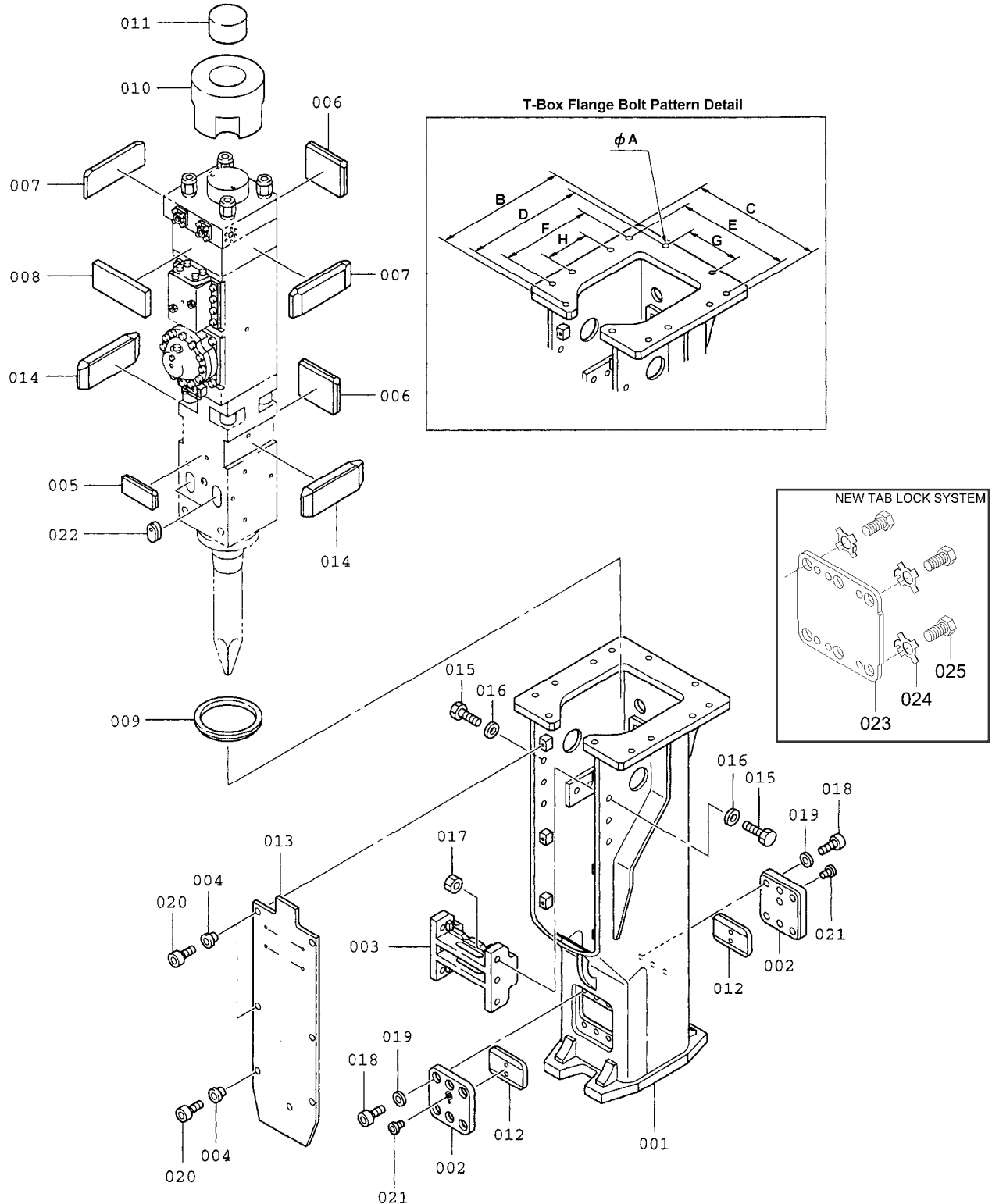

KF70-88001
T-BOX ASSEMBLY PARTS
F70Qt HYDRARAM

<u>ITEM</u>	<u>PART NUMBER</u>	<u>QTY</u>	<u>DESCRIPTION</u>	<u>ITEM</u>	<u>PART NUMBER</u>	<u>QTY</u>	<u>DESCRIPTION</u>
001	KF70-88101	1	T-Box Weldment	014	KF70-88130	2	Setup Damper
002	KF70-88112	2	Pin Cover *	015	K101032-42110	6	Bolt, M42
003	KF70-88113	2	Spacer	016	K140112-42000	6	Washer, M42
004	KF70-88114	1	Collar	017	K120132-42000	6	Hex Nut, M42
005	KF70-88121	6	Front Damper (A)	018	K102032-30045	12	Socket Bolt, M30 *
006	KF70-88122	2	Front Damper (B)	019	K140112-30000	12	Washer, M30 *
007	KF70-88923	2	Back Damper (A)	020	K102032-16025	6	Socket Bolt, M16
008	KF70-88124	1	Back Damper (B)	021	K084891-10000	2	GPF Plug
009	KF70-88125	1	Dust Ring	022	KHB50G-88229	2	Pin Plug
010	KF70-88126	1	Top Damper	023	KF70100	2	Pin Cover *
011	KF70-88127	1	Top Stopper	024	KF70101	12	Tab Lock Washer *
012	KF70-88128	2	Pin Damper	025	KF70102	12	Cap Screw, M30
013	KF70-88129	1	Soundproof Cover				

* Use either items 002, 018, and 019, or items 023, 024, and 025.
The tab washer system replaces the socket bolt version.

NOTE:

The Stop Pin(028), Dust Plugs (035), and Rubber Plug (030) indicated on page 3 of the Parts Breakdown are NOT used when the hammer is mounted in the T-Box Case. Remove the stop pin, rubber plug, and dust plugs from fronthead of hammer before assembling T-Box Case.

	<u>Inch</u>	<u>Milimeter</u>	
A	1.496	38	Bolt Hole Diameter
B	31.496	800	Flange, Long Side
C	31.102	790	Flange, Short Side
D	28.346	720	Center to Center
E	26.772	680	Center to Center
F	22.047	560	Center to Center
G	12.598	320	Center to Center
H	11.024	280	Center to Center

⇒ Furukawa Rock Drill USA offers a variety of top caps that match the original equipment for many excavator makes and models and work with many coupler systems. Please contact Furukawa Rock Drill USA's Product Support Department for additional information.

HOSE CONFIGURATIONS F70Qt HYDRARAM

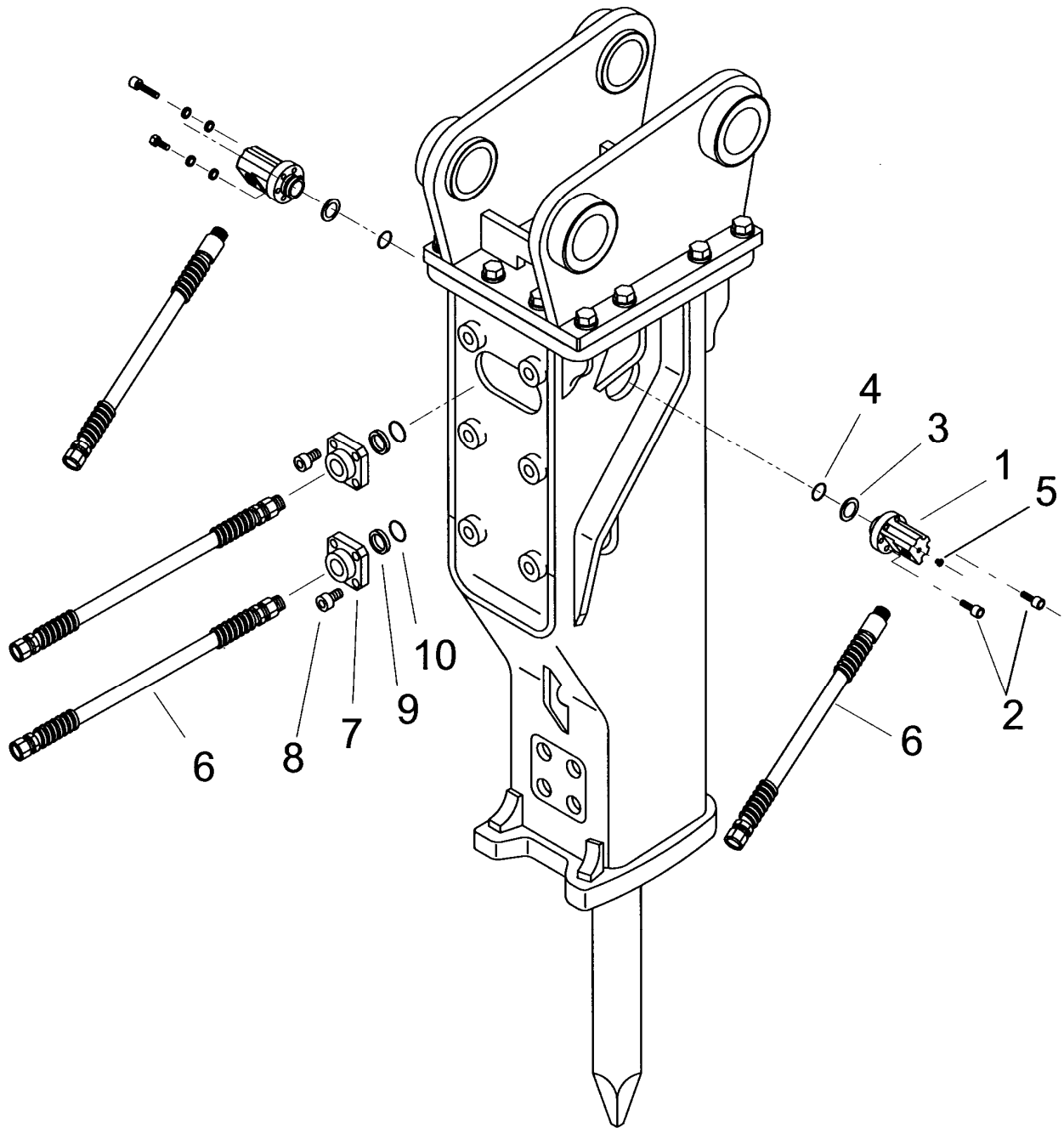

HOSE CONFIGURATIONS

F70Qt HYDRARAM

The F70Qt Hammer can be equipped with either FRONT or SIDE mounted hose whips. Hammers will be shipped with FRONT hoses unless SIDE hoses are specified.

SIDE MOUNTED HOSES

(2) KBM12481 Hose Assemblies consist of the following:

<u>ITEM</u>	<u>PART NUMBER</u>	<u>QTY</u>	<u>DESCRIPTION</u>
1	K19882	2	Port Adapter
2	K102033-14040	12	14mm Socket Head Bolt
3	K10735	2	Backup Ring
4	K10734	2	O-Ring
5	K19296	2	#4 Hollow Pipe Plug
6	K12481	2	Hose Whip

⇒ The following parts are used when the SIDE mounted hoses are installed:

--	KHB40G-30302	2	Front Port Flange (<i>Not Shown</i>)
--	K160011-00045	2	O-Ring for Port Flange (<i>Not Shown</i>)
--	K262022-00045	2	Backup Ring for Port Flange (<i>Not Shown</i>)
--	K084891-12000	2	Plug for Front Hose Ports (<i>Not Shown</i>)
--	K160011-00038	2	O-Ring for Adapter Plug (<i>Not Shown</i>)

FRONT MOUNTED HOSES:

<u>ITEM</u>	<u>PART NUMBER</u>	<u>QTY</u>	<u>DESCRIPTION</u>
6	K12481	2	Hose Whip
7	K11439	2	Front Port Flange
8	K102033-14035	8	Socket Bolt
9	K12585	2	Backup Ring
10	K12584	2	O-Ring

⇒ The following parts are used when the FRONT mounted hoses are installed:

--	K084891-10000	2	Plug for Side Hose Ports (<i>Not Shown</i>)
--	K160011-00029	2	O-Ring for Side Hose Ports (<i>Not Shown</i>)

UNIVERSAL TOP CAP
F70Qt HYDRARAM

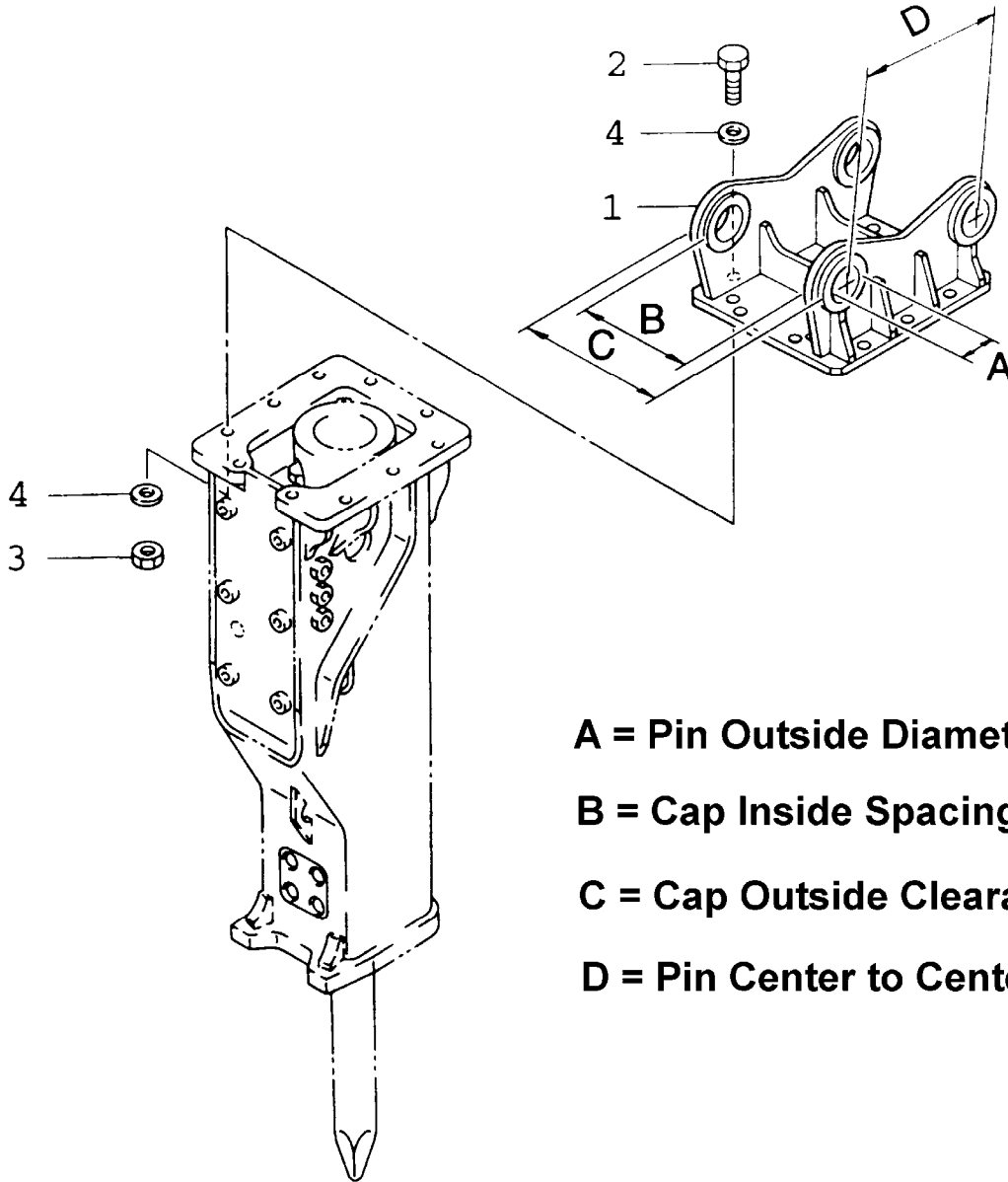

- A = Pin Outside Diameter**
- B = Cap Inside Spacing**
- C = Cap Outside Clearance**
- D = Pin Center to Center**

<u>ITEM</u>	<u>PART NUMBER</u>	<u>QTY</u>	<u>DESCRIPTION</u>	<u>ITEM</u>	<u>PART NUMBER</u>	<u>QTY</u>	<u>DESCRIPTION</u>
1	KF70050	1	Universal Cap	4	KF45014	20	Hardened Washer
2	KF70001	10	Cap Screw	*	K12481	2	Whip Hose
3	KF45013	10	Heavy Hex Nut				* Not Shown

⇒ Furukawa Rock Drill USA offers a variety of top caps that match the original equipment for many excavator makes and models and work with many coupler systems. Please contact Furukawa Rock Drill USA's Product Support Department for additional information.

MOUNTING PIN KIT
FOR
KF70050 UNIVERSAL TOP CAP
F70QT HYDRARAM

Base Machine Make: _____
 Base Machine Model: _____
 Dipperstick Pin Diameter: _____
 Link Pin Diameter: _____
 Dipperstick Width: _____
 Link Width: _____

MOUNTING KIT PART NO: _____

Consisting of the following:

<u>ITEM</u>	<u>P/N</u>	<u>QTY.</u>	<u>DESCRIPTION</u>
1	_____	1	_____ DIA. MOUNTING PIN x 26" LONG
2	_____	1	_____ DIA. MOUNTING PIN x 26" LONG
3	_____	2	_____ DIA. MOUNTING BUSHING X _____ LG.
4	_____	2	_____ DIA. MOUNTING BUSHING X _____ LG.
5	<u>K11074</u>	2	3/4" -10 UNC BOLT x 9 1/2"
6	<u>K10195</u>	2	3/4" -10 UNC LOCKNUT

SERVICE TOOL KIT

P/N KBM7090001

Furukawa Rock Drill USA includes a tool box with every new hydraulic breaker. This tool box contains many of the special tools and wrenches required to perform normal maintenance or repairs on the breaker. This is a basic tool box, and is by no means complete or comprehensive, but does contain many specialized tools, and wrench sizes not commonly found in the field. The following illustration depicts a typical tool box and its contents:

